



EPOXY 21

Prodotto per uso strutturale in accordo al D.M. 14/01/2008



Opzione > Option 1

M12 ... M24



M16 ... M24



Ø 8 ... 32 mm



FIXING IN SEISMIC

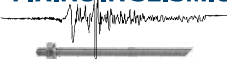

Annex E - C2

Qualifica sismica secondo
Linea Guida Europea EOTA ETAG-001 Annex E-C2
Seismic qualification according to
European Guide Line EOTA ETAG-001 Annex E-C2
Qualification sismique suivant
le Guide d'Agrement Technique Européen
EOTA ETAG-001 Annex E-C2
Seismischer Qualifikation nach der
Europäischen Richtlinie EOTA ETAG-001 Anhang E-C2



BCR-900 EPOXY 21

Cartuccia shuttle
Shuttle cartridge
Cartouche shuttle
Shuttlekartusche
900 ml
cod. 747646



BCR-470 EPOXY 21

Cartuccia shuttle
Shuttle cartridge
Cartouche shuttle
Shuttlekartusche
470 ml
cod. 747644



BCR-400 EPOXY 21

Cartuccia shuttle
Shuttle cartridge
Cartouche shuttle
Shuttlekartusche
400 ml
cod. 747640



BCR-400W (*) EPOXY 21

Cartuccia shuttle
Shuttle cartridge
Cartouche shuttle
Shuttlekartusche
400 ml
cod. 747640



Color legno
Wood colored
Colour bois
Holzfarbig



BCR-265 EPOXY 21

Cartuccia Peeler
Peeler cartridge
Cartouche Peeler
Peelerkartusche
265 ml
cod. 747625



(*) Su richiesta > On demand
Sur demande > Auf Wunsch



STOCCAGGIO E CONSERVAZIONE
STORAGE AND CONSERVATION
STOCKAGE ET CONSERVATION
LAGERUNG UND AUFBEWAHRUNG



CARTUCCIA
CARTRIDGE
CARTOUCHE
KARTUSCHE



DURATA (mesi)
EXPIRY (months)
ECHEANCHE (mois)
HALTBARKEIT (Monate)



**SCHEDA TECNICA
TECHNICAL DATA SHEET
FICHE TECHNIQUE
TECHNISCHES DATENBLATT**

EPOXY 21
CHARACTERISTICS > CARATTERISTICHE > EIGENSCHAFTEN



Resina Epossidica pura
Pure Epoxy resin
Résine Epoxy pure
Epoxidharz

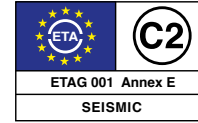

In base ai dati ed alle caratteristiche presenti sui Benestari Tecnici Europei (ETA) avete a disposizione uno dei migliori ancoranti chimici presenti sul mercato europeo con doppia certificazione. Le omologazioni sono valide per un'ampia gamma di barre filettate (da M8 a M30) e di barre ad aderenza migliorata (diametro da 8 mm a 32mm). Potete utilizzare il prodotto con calcestruzzo umido o in foro allagato senza raddoppiare i tempi per la messa in carico. Opzione 7 da M8 a M30 per calcestruzzo non fessurato e Opzione 1 per installazione in calcestruzzo fessurato con barre da M12 a M24. Il prodotto è omologato per fissaggi con profondità variabile di ancoraggio, per dare al progettista un'elevata flessibilità. ETA per connessioni post-installate in accordo a Eurocodice 2 e TR023 con profondità massima consentita di 2500 mm, posa in opera certificata sia con trapano che con carotatrice (secco/umido). Le temperature di esercizio certificate sono negli intervalli -40°C/+40°C (T° max lungo periodo = 24°C) e -40°C/+80°C (T° max lungo periodo = 50°C).

QUALIFICA SISMICA SECONDO LINEA GUIDA EUROPEA EOTA ETAG-001 ANNEX E-C2



According to data and features in the European Technical Approvals (ETA) you have at your disposal one of the best chemical anchors in the European market with double approval. The product is homologated for being used with a wide range of threaded rods (from M8 to M30) and rebar (diameter from 8mm to 32mm). You can use it in wet concrete and flooded hole without doubling the curing time. Option 7 from M8 to M30 for non-cracked concrete and Option 1 for installation in cracked concrete with rods from M12 to M24. It is certified for fixing with variable anchorage depths. This means that the project engineer has with this product a considerable flexibility in the design phase. ETA for post installed rebar connections in accordance with Eurocode 2 and TR023 with maximum allowed depth of 2500 mm, certified installation with both drill and core-drill (dry/wet). Certified service temperatures are in the ranges -40°C/+40°C (T° max long period = 24°C) and -40°C/+80°C (T° max long period = 50°C).

SEISMIC QUALIFICATION ACCORDING TO EUROPEAN GUIDE LINE EOTA ETAG-001 ANNEX E-C2



Selon les données et les caractéristiques dans les Agréments Techniques Européens (ATE), vous avez à votre disposition une des meilleures chevilles chimiques dans le marché européen avec double homologation. Les homologations sont valables pour une gamme complète de tiges filetées (de M8 à M30) et de fers à béton (diamètre de 8mm à 32mm). Vous pouvez l'utiliser en présence de béton humide et trou inondé sans doubler les temps avant l'application de la charge. Option 7 de M8 à M30 pour béton non fissuré et Option 1 pour installation en béton fissuré avec des barres de M12 à M24. Le produit est homologué pour fixations avec variables profondeurs d'ancrage, pour donner à l'ingénieur une haute flexibilité pendant la phase de projet. ETA pour scellement d'armatures rapportées en conformité avec EC2 et TR023 avec profondeur maximale permise de 2500 mm, installation certifiée avec perforateur et avec machine pour carottage (sec/humide). Les températures de travail certifiées sont entre les intervalles -40°C/+40°C (T° max longue période = 24°C) et -40°C/+80°C (T° max longue période = 50°C).

QUALIFICATION SISMIQUE SUIVANT LE GUIDE D'AGRÈMENT TECHNIQUE EUROPÉEN EOTA ETAG-001 ANNEX E - C2



Laut Europäisch Technischer Zulassung (ETA) einer der besten chemischen Anker (mit doppelter Zulassung!) im europäischen Markt. Die Zulassungen gelten für eine Gesamtreihe von Gewindestäben (von M8 bis M30) und Bewehrungsseisen (Durchmesser von 8 mm bis 32 mm). Epoxy 21 kann in nassem Beton und mit Wasser gefüllten Bohrlöchern (ohne Verzögerung in der Bauzeit) installiert werden. Option 7 von M8 bis M30 für ungerissenen. Beton und Option 1 für den Einbau in gerissenem Beton mit Gewindestangen von M12 bis M24. Epoxy 21 hat laut CE-ETA variable Verankerungstiefen. So ist der Anwender in hohem Maße flexibel! ETA für nachträglich eingemörtelte Bewehrungsanschlüsse in Übereinstimmung. mit EC2 und TR023 mit maximaler zulässiger Tiefe von 2500 mm, zertifizierte Installation mit Bohrmaschine und mit Kernbohrmotor (nass/trocken). Verarbeitungstemperatur: Zwischen +0°C/+30°C. Die zugelassene Temperaturbeständigkeit nach Aushärtung liegt zwischen -40°C/+40°C (langfristig max. 24°C) und -40°C/+80°C (langfristig max. 50°C).

SEISMISCHER QUALIFIKATION NACH DER EUROPÄISCHEN RICHTLINIE EOTA ETAG-001 ANHANG E-C2

CE DoP Dichiarazione di Prestazione su
Declarations of Performance on
www.bossong.com



*Information sur le niveau d'émission de substances volatiles dans l'air intérieur, présentant un risque de toxicité par inhalation, sur une échelle de classes allant de A+ (très faibles émissions) à C (fortes émissions)

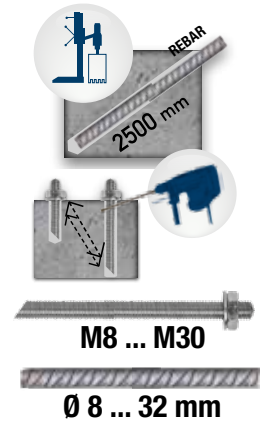
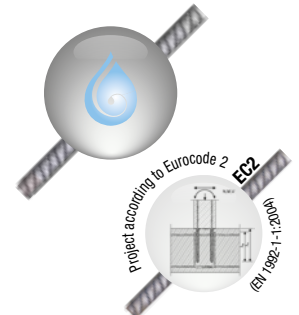
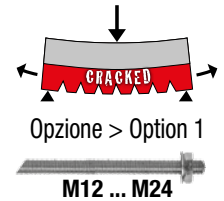

Consolidamento e Recupero
Strengthening
Restauration et Consolidation
Nachbewehrung



Test di caratterizzazione
meccanica del prodotto
Prot. n. 12310/11
Prot. n. 12311/11
Prot. n. 12312/11



+24°C -40°C ✓
+50°C -40°C ✓





> Applicazioni > Applications > Applications > Anwendungen



Edilizia Civile Pesante
Heavy Building Construction
Construction Civile Lourde
Schweres Zivilbauwesen



Edilizia Industriale Pesante
Heavy Industrial Construction
Construction Industrielle lourde
Schweres Industriebauwesen



Settore Elettrico Pesante
Heavy Electricity Area
Secteur Electricite Lourde
Schweres Elektrizwesen



Settore Idraulico e Lattoneria pesante
Heavy Hydraulic and Tilling Area
Secteur lour Hydrique et Ferblanterie
Schweres Hydraulikwesen und Blecharbeiten

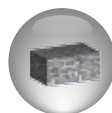

Pietra
Stone
Pierre
Stein



Mattone pieno
Solid Brick
Brique pleine
Vollmauerwerk



Legno
Wood
Bois
Holz

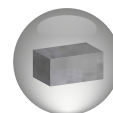

Calcestruzzo
Concrete
Béton
Beton



Applicazioni subacquee
Underwater applications
Applications sous-marines
Unterwasseranwendungen

> Gamma prodotti > Product's range > Gamme produits > Warenangebot

CARTUCCIA+MIXER>CARTRIDGE+MIXER
CARTOUCHE+MIXER>KARTUSCHE+MIXER

CODICE > CODE NUMMER	ARTICOLO > ITEM TYPE > ARTIKEL	DESCRIZIONE > DESCRIPTION DESCRIPTION > BESCHREIBUNG	Nr.
747656	BOX 470 EPOXY 21	20 x cartucce, 40 x mixers > 20 x cartridges, 40 x mixers 20 x cartouches, 40 x mixers > 20 x Kartusche, 40 x Mischer	1
747655	BOX 400 EPOXY 21	20 x cartucce, 40 x mixers > 20 x cartridges, 40 x mixers 20 x cartouches, 40 x mixers > 20 x Kartusche, 40 x Mischer	1
747012	KIT 400 EPOXY 21 LIGHT	2 x cartridges, 1 x gun, 4 x mixers, 1x brush, 1 x air pump, 10 x studs M8, 10 x studs M10	1
747009	KIT 400 EPOXY 21	2 x cartridges, 1 x gun, 4 x mixers, 1x brush, 1 x air pump, 10 x studs M8, 10 x studs M10	1
747011	KIT 265 EPOXY 21	2 x cartridges, 1 x gun, 4 x mixers, 1x brush, 1 x air pump, 10 x studs M8, 10 x studs M10	1



TEMPI DI POSA
SETTING TIMES
TEMPS D'INSTALLATION
VERLEGUNGSZEIT

01	02	03
50°C	7 min	7 h
40°C	15 min	7 h
30°C	20 min	12 h
25°C	30 min	14 h
20°C	50 min	16 h
15°C	1 h 10'	22 h
10°C	1 h 40'	28 h
5°C	2 h 30'	41 h
0°C	3 h 20'	54 h

+5°C

Temperatura minima del prodotto per l'applicazione
Minimum product temperature for application
Température minimal de la cartouche pour l'application
Min Kartouchetemperatur für die Anwendung

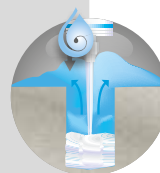

FORO ALLAGATO
FLOODED HOLE
TROU INONDÉ
WASSER GEFÜLLTEN
BOHRLÖCHER



Asian Institute of Technology



Test di valutazione della elettrostaticità,
res. superficiale e volumica
Rapporto > Test report Nr. 247896

- 01 Temperatura supporto > Base material temperature > Temperature material de base > Grundmaterial-temperatur
- 02 Tempo di lavorabilità > Open time > Temps de manipulation > Verarbeitungszeit
- 03 Attesa per la messa in carico > Curing time > Temps avant l'application de charge > Bauzeit



FIXING IN SEISMIC



Annex E - C2





SCHEDA TECNICA TECHNICAL DATA SHEET FICHE TECHNIQUE TECHNISCHES DATENBLATT

> Numero fissaggi > Number of fixings > Nombre de fixations > Anzahl der Befestigungen

Fissaggi nei materiali pieni > Fixings in solid materials > Fixations dans matériaux pleins > Befestigungen in Vollsteinen



BARRA FILETTATA > THREADED STUD BARRE FILETÉE > GEWINDESTANGE	FORO > HOLE TROU > BOHRLOCH	BCR 265	BCR 400	BCR 470	BCR 900
	d ₀ [mm] x h ₁ [mm]	Nr. Fissaggi > Fixings	Nr. Fissaggi > Fixings	Nr. Fissaggi > Fixings	Nr. Fissaggi > Fixings
M 8	10 x 85	± 50	± 76	± 89	± 170
M 10	12 x 95	± 34	± 51	± 60	± 116
M 12	14 x 115	± 22	± 31	± 36	± 76
M 16	18 x 130	± 14	± 21	± 24	± 47
M 20	24 x 175	± 5	± 7	± 8	± 16
M 24	28 x 215	± 3	± 5	± 6	± 11
M 27	30 x 245	± 3	± 4	± 5	± 10
M 30	35 x 275	± 1,5	± 2,5	± 3	± 5,5

- > **NOTA:** Il numero di fissaggi sopra specificato è stato determinato conteggiando esclusivamente il volume teorico di prodotto necessario al riempimento del foro (o gabbietta) escluso il volume della barra inserita. Pur essendo incluso nel calcolo teorico uno spreco standard, il reale quantitativo di prodotto potrà differire da questo in funzione della effettiva modalità di posa in opera adottata.
- > **WARNING:** The number of fixings above mentioned has been calculated according to the theoretical volume needed to fill the hole (or sleeve) excluded the volume of the inserted metal rod. In the theoretical volume it is included a standard extra quantity but the real quantity of the product may be different than it in function of the real application of the product.
- > **NOTE:** Le numéro des fixations sur mentionné a été déterminé en calculant exclusivement le volume théorique de produit nécessaire au remplissage du trou (ou tamis), exclu le volume de la tige filetée. Bien si dans le calcul théorique est incluse une quantité standard de matériel extra, la quantité réelle de produit peut être différente, en fonction des effectives modes d'application du produit.
- > **ANMERKUNG:** Die obengenannte Anzahl der Befestigungen wurde nach dem theoretischen Volumen für die Bohrlochfüllung (oder Siebhülse-Füllung) minus dem Volumen der Gewindestange berechnet. Im theoretischen Volumen wird eine Standard-Extra-Menge einkalkuliert, aber die wirkliche Produktmenge kann anders sein, abhängig von der wirklichen Anwendung des Produktes.





> **Dati installazione > Installation data > Données d'installation > Installationsangaben**

D	Materiale > Material > Matériel > Material
	d [mm] Diametro barra > Rod diameter > Diamètre de la barre > Stangedurchmesser
N	Tipologia di barra > Type of rod > Classe de la barre > Stange-Klasse
	Gabbietta > Plastic sleeve > Tamis > Hülse
E	h _{min} [mm] Spessore minimo del supporto > Minimum thickness of base material Épaisseur minimal du matériel de base > Mindestbauteildicke
	d ₀ [mm] Diametro foro > Hole diameter > Diamètre du trou > Bohrloch-Durchmesser
G	h ₁ [mm] Profondità del foro > Hole depth > Profondeur du trou > Bohrlochtiefe
	h _{nom} [mm] Profondità di inserimento > Embedment depth Profondeur d'insertion > Setztiefe
L	h _{ef} [mm] Profondità effettiva ancoraggio > Effective anchorage depth Profondeur effective d'ancrage > Effektive Verankerungstiefe

D	S _{cr} [mm] Interasse caratteristico > Characteristic spacing Entraxe Caractéristique > Charakteristischerachsabstand
	C _{cr} [mm] Distanza dal bordo caratteristica > Characteristic edge distance Distance du bord caractéristique > Charakteristischerandabstand
N	S _{min} [mm] Interasse minimo > Minimum allowable spacing Entraxe minimale > Minimaler Achsabstand
	C _{min} [mm] Distanza minima dal bordo > Minimum allowable edge distance Distance du bord minimale > Minimaler Randabstand
E	t _{fix} [mm] Spessore fissabile > Fixture thickness Épaisseur fixable > Anbauteildicke
	d _f [mm] Diametro foro spessore fissabile > Diameter of clearance hole in the fixture Diamètre du trou dans l'épaisseur fixable > Bohrloch-Durchmesser im Anbauteil
G	S _w [mm] Chiave > Key > Clef > Schlüsselweite
	T _{inst} [Nm] Coppia di serraggio > Installation torque Couple de serrage > Drehmoment Beim Verankern

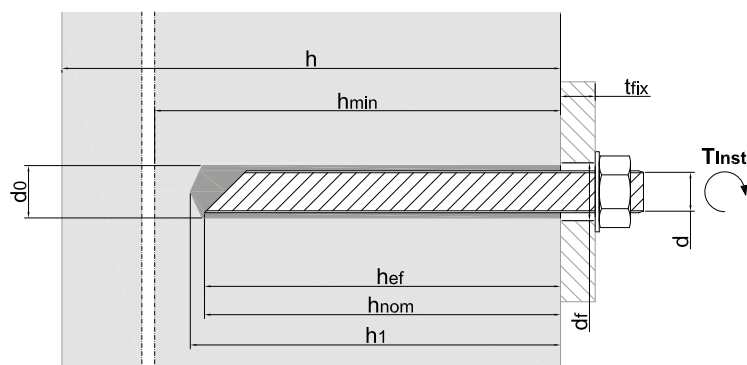

- > **NOTA:** Prima dell'installazione del prodotto consultare la presente sezione e la procedura di installazione completa riportata nelle pagine successive. Si declina ogni responsabilità per l'uso improprio del prodotto.
- > **WARNING:** Before use see this section and the complete procedure of installation reported in the next pages. We assume no liability for the not correct use of the product.
- > **NOTE:** avant l'installation du produit nous vous prions de lire cette section et la procédure d'installation complète que Vous trouvez dans les pages suivantes. Nous n'assurons pas de responsabilité pour une utilisation incorrecte du produit.
- > **ANMERKUNG:** vor der Installation des Produktes bitte diesen Abschnitt und das komplette Installationsverfahren in den folgenden Seiten lesen. Wir übernehmen keine Haftung für die inkorrekte Anwendung des Produktes.



Opzione > Option 1
M12 ... M24

Opzione > Option 7
M8 ... M30



M16 ... M24

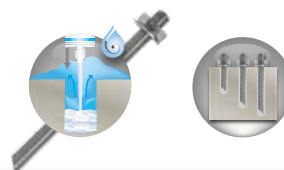

MATERIALE MATERIAL	DIAMETRO BARRA ROD DIAMETER	TIPOLOGIA DI BARRA TYPE OF ROD	SPESSORE MIN. DEL SUPPORTO MIN. THICKNESS BASE MATERIAL			DIAMETRO FORO HOLE DIAMETER	PROFONDITÀ DEL FORO HOLE DEPTH			PROFONDITÀ DI INSERIMENTO EMBEDMENT DEPTH			PROFONDITÀ EFF. ANCORAGGIO EFFECTIVE ANCHORAGE DEPTH			INTERASSE CARATTERISTICO CHARACTERISTIC SPACING			DISTANZA DAL BORDO CARATTERISTICA CHARACTERISTIC EDGE DISTANCE		
			min	med	max		min	med	max	min	med	max	min	med	max	min	med	max	min	med	max
EPOXY 2 M8-M30 Calcestruzzo non fessurato Non cracked Concrete	M8	≥ 5.8 - A4/70	100	110	190	10	65	85	165	60	80	160	60	80	160	180	202	202	90	101	101
	M10	≥ 5.8 - A4/70	100	120	230	12	65	95	205	60	90	200	60	90	200	180	242	242	90	121	121
M12-M24 Calcestruzzo fessurato Cracked Concrete	M12	≥ 5.8 - A4/70	100	140	270	14	75	115	245	70	110	240	70	110	240	210	291	291	105	145	145
	M16	≥ 5.8 - A4/70	116	161	356	18	85	130	325	80	125	320	80	125	320	240	375	388	120	188	194
M16-M24 SEISMIC ANNEX-E C2	M20	≥ 5.8 - A4/70	138	218	448	24	95	175	405	90	170	400	90	170	400	270	462	462	135	231	231
	M24	≥ 5.8 - A4/70	152	266	536	28	100	215	485	96	210	480	96	210	480	288	554	554	144	277	277
	M27	≥ 5.8 - A4/70	170	300	600	30	115	245	545	110	240	540	110	240	540	330	624	624	165	312	312
CE	M30	≥ 5.8 - A4/70	190	340	670	35	125	275	605	120	270	600	120	270	600	360	693	693	180	346	346



SCHEDA TECNICA TECHNICAL DATA SHEET FICHE TECHNIQUE TECHNISCHES DATENBLATT



Opzione > Option 1

M12 ... M24

Opzione > Option 7

M8 ... M30



M16 ... M24



MATERIALE MATERIAL	DIAMETRO BARRA ROD DIAMETER	TIPOLOGIA DI BARRA TYPE OF ROD	INTERASSE MIN. ALLOWABLE SPACING	DISTANZA MIN. DAL BORDO MIN. ALLOWABLE EDGE DISTANCE	SPESS. FISSABILE FIXTURE THICKNESS	DIAMETRO FORO SPESS. FISSABILE DIAMETER OF CLEARANCE HOLE IN THE FIXTURE	CHIAVE KEY	COPIA DI SERRAGGIO INSTALLATION TORQUE
EPOXY 21	d [mm]		S _{min} [mm]	C _{min} [mm]	t _{fix} [mm]	d _f [mm]	S _w [mm]	T _{inst} [Nm]
M8-M30 Calcestruzzo non fessurato Non cracked Concrete	M8	≥ 5.8 - A4/70	40	40	0 ÷ 1500	9	13	10
	M10	≥ 5.8 - A4/70	50	50	0 ÷ 1500	12	17	20
M12-M24 Calcestruzzo fessurato Cracked Concrete	M12	≥ 5.8 - A4/70	60	60	0 ÷ 1500	14	19	40
	M16	≥ 5.8 - A4/70	80	80	0 ÷ 1500	18	24	80
M16-M24 SEISMIC ANNEX-E C2	M20	≥ 5.8 - A4/70	100	100	0 ÷ 1500	22	30	130
	M24	≥ 5.8 - A4/70	120	120	0 ÷ 1500	26	36	200
	M27	≥ 5.8 - A4/70	135	135	0 ÷ 1500	29	41	270
	M30	≥ 5.8 - A4/70	150	150	0 ÷ 1500	33	46	300

- > Per evitare una possibile rottura per splitting, lo spessore del supporto in calcestruzzo dovrà essere $h \geq 2h_{ef}$
- > To avoid splitting failure, the thickness of the concrete member shall be $h \geq 2h_{ef}$
- > Pour éviter une possible rupture par splitting, l'épaisseur du support en béton devrait être $h \geq 2h_{ef}$
- > Um einen splittingbedingten Bruch zu verhindern, die Dicke der Unterlage aus Beton muss $h \geq 2h_{ef}$ sein



Ø 8 ... 32 mm

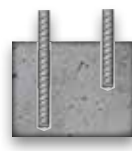
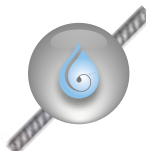

MATERIALE MATERIAL	DIAMETRO BARRA ROD DIAMETER	TIPOLOGIA DI BARRA TYPE OF ROD	DIAMETRO FORO HOLE DIAMETER	LUNGHEZZA DI ANCORAGGIO ANCHORAGE LENGTH (**)			INTERASSE MIN. MIN. ALLOWABLE SPACING	DISTANZA MIN. DAL BORDO MIN. ALLOWABLE EDGE DISTANCE		
				MIN lb	MIN lo	MAX lb		S _{min} [mm]	C _{min} [mm]	
EPOXY 21	d [mm]		d ₀ [mm]	MIN lb	MIN lo	MAX lb	S _{min} [mm]	MIN lb	MIN lo	MAX lb
C20/25 Calcestruzzo Concrete Beton Beton	Ø 8	Rebar (*)	12	115	200	700	40	37	42	72
	Ø 10	Rebar (*)	14	145	200	900	40	39	42	84
	Ø 12	Rebar (*)	16	170	200	1100	48	40	42	96
	Ø 14	Rebar (*)	18	200	210	1300	56	42	43	108
	Ø 16	Rebar (*)	20	230	240	1400	64	44	45	114
	Ø 20	Rebar (*)	25	285	300	1800	80	47	48	138
	Ø 25	Rebar (*)	30	355	375	2200	100	61	63	172
	Ø 28	Rebar (*)	35	400	420	2500	112	64	65	190
Ø 32	Rebar (*)	40	455	480	2500	128	67	69	190	

(*) Rebar = B450C; BST 500

(**) Lunghezza di ancoraggio in accordo a EC2 e TR023. lb = lunghezza di ancoraggio lo = lunghezza di sovrapposizione
Anchorage lengths according to EC2 and TR023. lb = anchorage length lo = overlap joint length
Longueurs d'ancrage en accord avec EC2 et TR023. lb = longueurs d'ancrage lo = longer sousplacées
Verankerung Länge einigung mit EC2 und TR023. lb = Verankerung Länge lo = Überlagerung Länge



MATERIALE MATERIAL EPOXY 21	DIAMETRO BARRA ROD DIAMETER	TIPOLOGIA DI BARRA TYPE OF ROD	SPESSORE MIN. DEL SUPPORTO MIN. THICKNESS BASE MATERIAL			DIAMETRO FORO HOLE DIAMETER	PROFONDITÀ DEL FORO HOLE DEPTH			PROFONDITÀ DI INSERIMENTO EMBEDMENT DEPTH			PROFONDITÀ EFF. ANCORAGGIO EFFECTIVE ANCHORAGE DEPTH			INTERASSE CARATTERISTICO CHARACTERISTIC SPACING			DISTANZA DAL BORDO CARATTERISTICA CHARACTERISTIC EDGE DISTANCE			INTERASSE MIN. ALLOWABLE SPACING		DISTANZA MIN. DAL BORDO MIN. ALLOWABLE EDGE DISTANCE	
			min	med	max		min	med	max	min	med	max	min	med	max	min	med	max	min	med	max	S _{min}	C _{min}		
Calcestruzzo non fessurato Non cracked Concrete	Ø 8	Rebar (*)	100	110	190	12	65	85	165	60	80	160	60	80	160	120	160	320	60	80	160	40	40		
	Ø 10	Rebar (*)	100	120	230	14	65	95	205	60	90	200	60	90	200	120	180	400	60	90	200	45	45		
	Ø 12	Rebar (*)	102	142	275	16	75	115	245	70	110	240	70	110	240	140	220	480	70	110	240	55	55		
	Ø 14	Rebar (*)	116	161	316	18	85	130	285	80	125	280	80	125	280	160	250	560	80	125	280	63	63		
	Ø 16	Rebar (*)	120	180	360	20	85	145	325	80	140	320	80	140	320	160	280	640	80	140	320	70	70		
	Ø 20	Rebar (*)	140	220	450	25	95	175	405	90	170	400	90	170	400	180	340	800	90	170	400	85	85		
	Ø 25	Rebar (*)	160	270	560	30	105	215	505	100	210	500	100	210	500	200	420	1000	100	210	500	105	105		
	Ø 28	Rebar (*)	182	340	630	35	117	275	565	112	270	560	112	270	560	224	540	1120	112	270	560	135	135		
Ø 32	Rebar (*)	208	380	720	40	133	305	645	128	300	640	128	300	640	256	600	1280	128	300	640	150	150			

(*) Rebar = B450C; BST 500

> Parametri d'installazione validi per applicazioni in accordo alla teoria dell'ancoraggio > Installation parameters suitable for application according to the anchors theory
> Paramètres d'installation en conformité avec la théorie de l'ancrage > Installationsparameter in Übereinstimmung mit der Verankerungstheorie

MATERIALE MATERIAL EPOXY 21	DIAMETRO BARRA ROD DIAMETER	TIPOLOGIA DI BARRA TYPE OF ROD	SPESSORE MIN. DEL SUPPORTO MIN. THICKNESS BASE MATERIAL			DIAMETRO FORO HOLE DIAMETER	PROFONDITÀ DEL FORO HOLE DEPTH	PROFONDITÀ DI INSERIMENTO EMBEDMENT DEPTH	PROFONDITÀ EFF. ANCORAGGIO EFFECTIVE ANCHORAGE DEPTH	INTERASSE CARATTERISTICO CHARACTERISTIC SPACING	DISTANZA DAL BORDO CARATTERISTICA CHARACTERISTIC EDGE DISTANCE	INTERASSE MIN. ALLOWABLE SPACING	DISTANZA MIN. DAL BORDO MIN. ALLOWABLE EDGE DISTANCE	SPESS. FISSABILE MAX FIXTURE THICKNESS	DIAMETRO FORO SPESS. FISSABILE DIAMETER OF CLEARANCE HOLE IN THE FIXTURE	CHIAVE KEY	COPPIA DI SERRAGGIO INSTALLATION TORQUE
			h _{min}	h _{med}	h _{max}												
Mattone pieno Solid Brick Brique pleine Vollmauerwerk	M8	≥ 4.6 A2-70 A4-70	200			10	85	80	80	160	200	100	100	10	9	13	7
	M10	≥ 4.6 A2-70 A4-70	250			12	90	85	85	200	100	100	20	12	17	15	
	M12	≥ 4.6 A2-70 A4-70	300			14	100	95	95	240	100	100	30	14	19	25	
	M16	≥ 4.6 A2-70 A4-70	350			18	130	125	125	320	200	100	35	18	24	30	

MATERIALE MATERIAL EPOXY 21	DIAMETRO BARRA ROD DIAMETER	TIPOLOGIA DI BARRA TYPE OF ROD	SPESSORE MIN. DEL SUPPORTO MIN. THICKNESS BASE MATERIAL			DIAMETRO FORO HOLE DIAMETER	PROFONDITÀ DEL FORO HOLE DEPTH	PROFONDITÀ DI INSERIMENTO EMBEDMENT DEPTH	PROFONDITÀ EFF. ANCORAGGIO EFFECTIVE ANCHORAGE DEPTH	INTERASSE CARATTERISTICO CHARACTERISTIC SPACING	DISTANZA DAL BORDO CARATTERISTICA CHARACTERISTIC EDGE DISTANCE	INTERASSE MIN. ALLOWABLE SPACING	DISTANZA MIN. DAL BORDO MIN. ALLOWABLE EDGE DISTANCE	SPESS. FISSABILE MAX FIXTURE THICKNESS	DIAMETRO FORO SPESS. FISSABILE DIAMETER OF CLEARANCE HOLE IN THE FIXTURE	CHIAVE KEY	COPPIA DI SERRAGGIO INSTALLATION TORQUE
			h _{min}	h _{med}	h _{max}												
Legno lamellare Laminated Timber Holz	M8	≥ 4.6 A2-70 A4-70	160			10	85	80	80	100	80	50	50	10	9	13	7
	M10	≥ 4.6 A2-70 A4-70	200			12	105	100	100	125	100	50	50	20	12	17	15
	M12	≥ 4.6 A2-70 A4-70	240			14	125	120	120	150	120	60	60	30	14	19	25
	M16	≥ 4.6 A2-70 A4-70	320			18	165	160	160	200	160	80	80	35	18	24	30



SCHEDA TECNICA TECHNICAL DATA SHEET FICHE TECHNIQUE TECHNISCHES DATENBLATT

> Dati carico > Load data > Données de charge > Lastdaten

D N E G L	N_{um} [kN]	Carico ultimo medio a trazione > Average ultimate tension load > Charge maximum moyenne de traction Durchschnittliche maximale Zuglast
	V_{um} [kN]	Carico ultimo medio a taglio > Average ultimate shear load > Charge maximum moyenne de cisaillement Durchschnittliche maximale Querlast
	N_{rk} [kN]	Carico caratteristico a trazione > Characteristic tension load > Charge caracteristique de traction Charakteristische Zuglast
	V_{rk} [kN]	Carico caratteristico a taglio > Characteristic shear load > Charge caracteristique de cisaillement Charakteristische Querlast
	N_{rec} [kN]	Carico ammissibile a trazione > Admissible tensile load > Charge admissible de traction > Zulässige Zuglast
	V_{rec} [kN]	Carico ammissibile a taglio > Admissible shear load > Charge admissible de cisaillement > Zulässige Querlast

> Carichi validi per singolo ancorante senza influenza di interasse e distanza dal bordo e $h \geq 2h_{ef}$
 > Loads for single anchor with no influence of spacing and edge distance and with $h \geq 2h_{ef}$
 > Charges valables pour chaque ancrage sans influence d'interaxe et distance du bord et $h \geq 2h_{ef}$
 > Passende Ringe für den einzelnen Veranker, ohne Achsenabstandseinfluss und des Randabstands und $h \geq 2h_{ef}$

> 1kN = 100 Kg

> Azione di taglio non diretta verso il bordo > Coefficiente di sicurezza globale incluso > Coefficiente lato carichi utilizzato = 1,4
 > Shear directed away from the edge > General safety factor included > Load increasing safety coefficient used = 1,4
 > Action de cisaillement pas dirigée vers le bord > Coefficient de sécurité generale inclu > Coefficient côté charge utilisé = 1,4
 > Queraktion nicht an den Rand gerichtet > Generelle Sicherheitskoeffizient inbegriffen > Verwendeter Lasterhöhungssicherheitskoeffizient = 1,4

MIN Dati di carico con profondità effettiva ancoraggio MINIMA > Load data with MINIMUM effective anchorage depth
 Données de charge avec profondeur efficace d'ancrage MINIMALE > Lastdaten mit MINIMALER effektiven Verankerungstiefe

EPOXY 21 MATERIALE MATERIAL	BARRA ROD	DIAMETRO BARRA ROD DIAMETER	PROFONDITÀ EFF. ANCORAGGIO EFFECTIVE ANCHORAGE DEPTH	CARICO ULTIMO MEDIO A TRAZIONE ULTIMATE TENSION LOAD	CARICO ULTIMO MEDIO A TAGLIO ULTIMATE SHEAR LOAD	CARICO CARATTERISTICO A TRAZIONE CHARACTERISTIC TENSILE LOAD	CARICO CARATTERISTICO A TAGLIO CHARACTERISTIC SHEAR LOAD	CARICO AMMISSIBILE A TRAZIONE ADMISSIBLE TENSILE LOAD	CARICO AMMISSIBILE A TAGLIO ADMISSIBLE SHEAR LOAD	
										d [mm]
C20/25 Calcestruzzo fessurato Cracked Concrete Beton fissuré Gerissener Beton	 ≥ 5.8	≥ 5.8	M 12	70	27,8	26,2	20,9	21,9	9,9	12,5
		≥ 5.8	M 16	80	33,9	48,9	25,7	40,8	12,2	19,8
		≥ 5.8	M 20	90	40,5	76,2	30,7	61,5	14,6	29,2
		≥ 5.8	M 24	96	44,6	89,3	33,8	67,7	16,1	32,2

MED Dati di carico con profondità effettiva ancoraggio MEDIA > Load data with MEDIUM effective anchorage depth
 Données de charge avec profondeur efficace d'ancrage MOYENNE > Lastdaten mit MITTLERER effektiven Verankerungstiefe

EPOXY 21 MATERIALE MATERIAL	BARRA ROD	DIAMETRO BARRA ROD DIAMETER	PROFONDITÀ EFF. ANCORAGGIO EFFECTIVE ANCHORAGE DEPTH	CARICO ULTIMO MEDIO A TRAZIONE ULTIMATE TENSION LOAD	CARICO ULTIMO MEDIO A TAGLIO ULTIMATE SHEAR LOAD	CARICO CARATTERISTICO A TRAZIONE CHARACTERISTIC TENSILE LOAD	CARICO CARATTERISTICO A TAGLIO CHARACTERISTIC SHEAR LOAD	CARICO AMMISSIBILE A TRAZIONE ADMISSIBLE TENSILE LOAD	CARICO AMMISSIBILE A TAGLIO ADMISSIBLE SHEAR LOAD	
										d [mm]
C20/25 Calcestruzzo fessurato Cracked Concrete Beton fissuré Gerissener Beton	 ≥ 5.8	≥ 5.8	M 12	110	43,8	26,2	32,9	21,9	15,6	12,5
		≥ 5.8	M 16	125	66,3	48,9	43,1	40,8	20,5	23,3
		≥ 5.8	M 20	170	105,2	76,2	79,8	63,5	38,0	36,2
		≥ 5.8	M 24	210	144,5	110,4	109,5	92,0	52,1	52,5

MAX Dati di carico con profondità effettiva ancoraggio MASSIMO > Load data with MAXIMUM effective anchorage depth
 Données de charge avec profondeur efficace d'ancrage MAXIMUM > Lastdaten mit MAXIMALER effektiven Verankerungstiefe

EPOXY 21 MATERIALE MATERIAL	BARRA ROD	DIAMETRO BARRA ROD DIAMETER	PROFONDITÀ EFF. ANCORAGGIO EFFECTIVE ANCHORAGE DEPTH	CARICO ULTIMO MEDIO A TRAZIONE ULTIMATE TENSION LOAD	CARICO ULTIMO MEDIO A TAGLIO ULTIMATE SHEAR LOAD	CARICO CARATTERISTICO A TRAZIONE CHARACTERISTIC TENSILE LOAD	CARICO CARATTERISTICO A TAGLIO CHARACTERISTIC SHEAR LOAD	CARICO AMMISSIBILE A TRAZIONE ADMISSIBLE TENSILE LOAD	CARICO AMMISSIBILE A TAGLIO ADMISSIBLE SHEAR LOAD	
										d [mm]
C20/25 Calcestruzzo fessurato Cracked Concrete Beton fissuré Gerissener Beton	 8.8	8.8	M 12	240	67,4	40,4	67,4	33,7	32,1	19,2
		8.8	M 16	320	125,0	75,0	110,4	62,5	52,6	35,7
		8.8	M 20	400	203,0	121,8	189,2	101,5	90,1	58,0
		8.8	M 24	480	293,0	175,8	278,0	146,5	132,5	83,7



Con foro allagato, riduzione del carico consigliato del 20%
 With flooded hole, reduction of the recommended load of 20%





> **Dati carico > Load data > Données de charge > Lastdaten**

D E N E L	N_{rum} [kN]	Carico ultimo medio a trazione > Average ultimate tension load > Charge maximum moyenne de traction Durchschnittliche maximale Zuglast
	V_{rum} [kN]	Carico ultimo medio a taglio > Average ultimate shear load > Charge maximum moyenne de cisaillement Durchschnittliche maximale Querlast
	N_{rk} [kN]	Carico caratteristico a trazione > Characteristic tension load > Charge caractéristique de traction Charakteristische Zuglast
	V_{rk} [kN]	Carico caratteristico a taglio > Characteristic shear load > Charge caractéristique de cisaillement Charakteristische Querlast
	N_{rec} [kN]	Carico ammissibile a trazione > Admissible tensile load > Charge admissible de traction > Zulässige Zuglast
	V_{rec} [kN]	Carico ammissibile a taglio > Admissible shear load > Charge admissible de cisaillement > Zulässige Querlast

> Carichi validi per singolo ancorante senza influenza di interasse e distanza dal bordo e $h \geq 2h_{ef}$
> Loads for single anchor with no influence of spacing and edge distance and with $h \geq 2h_{ef}$
> Charges valables pour chaque ancrage sans influence d'interaxe et distance du bord et $h \geq 2h_{ef}$
> Passende Ringe für den einzelnen Veranker, ohne Achsenabstandseinfluss und des Randabstands und $h \geq 2h_{ef}$

> 1kN = 100 Kg

> Azione di taglio non diretta verso il bordo
> Shear directed away from the edge
> Action de cisaillement pas dirigée vers le bord
> Queraktion nicht an den Rand gerichtet

> Coefficiente di sicurezza globale incluso
> General safety factor included
> Coefficient de sécurité générale inclu
> Generelle Sicherheitskoeffizient inbegriffen

> Coefficiente lato carichi utilizzato = 1,4
> Load increasing safety coefficient used = 1,4
> Coefficient côté charge utilisé = 1,4
> Verwendeter Lasterhöhungssicherheitskoeffizient = 1,4

OPTION 7
+24°C

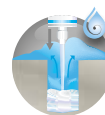
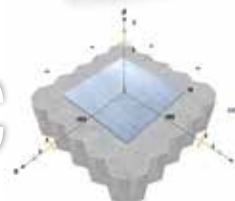
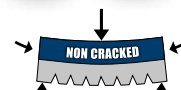

Con foro allagato, riduzione del carico consigliato del 20%
With flooded hole, reduction of the recommended load of 20%



MIN Dati di carico con profondità effettiva ancoraggio MINIMA > Load data with MINIMUM effective anchorage depth
Donnes de charge avec profondeur efficace d'ancrage MINIMALE > Lastdaten mit MINIMALER effektiven Verankerungstiefe

MATERIALE MATERIAL	BARRA ROD	DIAMETRO BARRA ROD DIAMETER	PROFONDITÀ EFF. ANCORAGGIO EFFECTIVE ANCHORAGE DEPTH	CARICO ULTIMO MEDIO A TRAZIONE	CARICO ULTIMO MEDIO A TAGLIO	CARICO CARATTERISTICO A TRAZIONE	CARICO CARATTERISTICO A TAGLIO	CARICO AMMISSIBILE A TRAZIONE	CARICO AMMISSIBILE A TAGLIO
				ULTIMATE TENSION LOAD	ULTIMATE SHEAR LOAD	CHARACTERISTIC TENSILE LOAD	CHARACTERISTIC SHEAR LOAD	ADMISSIBLE TENSILE LOAD	ADMISSIBLE SHEAR LOAD
		d [mm]	$h_{ef MIN}$ [mm]	N_{rum} [kN]	V_{rum} [kN]	N_{rk} [kN]	V_{rk} [kN]	N_{rec} [kN]	V_{rec} [kN]
C20/25 Calcestruzzo non fessurato Non cracked Concrete Béton non fissuré Ungerissener Beton	≥ 5.8	M 8	60	19,0	11,4	17,9	9,5	8,5	5,4
	≥ 5.8	M 10	60	25,4	18,1	21,0	15,1	10,0	8,6
	≥ 5.8	M 12	70	39,4	26,2	29,3	21,9	14,0	12,5
	≥ 5.8	M 16	80	48,3	48,9	36,1	40,8	17,2	23,3
	≥ 5.8	M 20	90	57,6	76,2	43,1	63,5	20,5	36,2
	≥ 5.8	M 24	96	63,4	110,4	47,5	92,0	22,6	45,2
	≥ 5.8	M 27	110	77,8	143,4	58,2	116,5	27,7	55,4
	≥ 5.8	M 30	120	88,7	175,2	66,3	132,8	31,6	63,2

MED Dati di carico con profondità effettiva ancoraggio MEDIA > Load data with MEDIUM effective anchorage depth
Donnes de charge avec profondeur efficace d'ancrage MOYENNE > Lastdaten mit MITTLERER effektiven Verankerungstiefe

MATERIALE MATERIAL	BARRA ROD	DIAMETRO BARRA ROD DIAMETER	PROFONDITÀ EFF. ANCORAGGIO EFFECTIVE ANCHORAGE DEPTH	CARICO ULTIMO MEDIO A TRAZIONE	CARICO ULTIMO MEDIO A TAGLIO	CARICO CARATTERISTICO A TRAZIONE	CARICO CARATTERISTICO A TAGLIO	CARICO AMMISSIBILE A TRAZIONE	CARICO AMMISSIBILE A TAGLIO
				ULTIMATE TENSION LOAD	ULTIMATE SHEAR LOAD	CHARACTERISTIC TENSILE LOAD	CHARACTERISTIC SHEAR LOAD	ADMISSIBLE TENSILE LOAD	ADMISSIBLE SHEAR LOAD
		d [mm]	$h_{ef MED}$ [mm]	N_{rum} [kN]	V_{rum} [kN]	N_{rk} [kN]	V_{rk} [kN]	N_{rec} [kN]	V_{rec} [kN]
C20/25 Calcestruzzo non fessurato Non cracked Concrete Béton non fissuré Ungerissener Beton	≥ 5.8	M 8	80	19,0	11,4	19,0	9,5	9,0	5,4
	≥ 5.8	M 10	90	30,2	18,1	30,2	15,1	14,3	8,6
	≥ 5.8	M 12	110	43,8	26,2	43,8	21,9	20,8	12,5
	≥ 5.8	M 16	125	81,6	48,9	70,5	40,8	33,6	23,3
	≥ 5.8	M 20	170	127,0	76,2	103,8	63,5	49,4	36,2
	≥ 5.8	M 24	210	184,0	110,4	153,6	92,0	73,1	52,5
	≥ 5.8	M 27	240	239,0	143,4	187,7	119,5	89,4	68,2
	≥ 5.8	M 30	270	292,0	175,2	224,0	146,0	106,6	83,4

MAX Dati di carico con profondità effettiva ancoraggio MASSIMO > Load data with MAXIMUM effective anchorage depth
Donnes de charge avec profondeur efficace d'ancrage MAXIMUM > Lastdaten mit MAXIMALER effektiven Verankerungstiefe

MATERIALE MATERIAL	BARRA ROD	DIAMETRO BARRA ROD DIAMETER	PROFONDITÀ EFF. ANCORAGGIO EFFECTIVE ANCHORAGE DEPTH	CARICO ULTIMO MEDIO A TRAZIONE	CARICO ULTIMO MEDIO A TAGLIO	CARICO CARATTERISTICO A TRAZIONE	CARICO CARATTERISTICO A TAGLIO	CARICO AMMISSIBILE A TRAZIONE	CARICO AMMISSIBILE A TAGLIO
				ULTIMATE TENSION LOAD	ULTIMATE SHEAR LOAD	CHARACTERISTIC TENSILE LOAD	CHARACTERISTIC SHEAR LOAD	ADMISSIBLE TENSILE LOAD	ADMISSIBLE SHEAR LOAD
		d [mm]	$h_{ef MAX}$ [mm]	N_{rum} [kN]	V_{rum} [kN]	N_{rk} [kN]	V_{rk} [kN]	N_{rec} [kN]	V_{rec} [kN]
C20/25 Calcestruzzo non fessurato Non cracked Concrete Béton non fissuré Ungerissener Beton	8.8	M 8	160	29,2	17,5	29,2	14,6	13,9	8,3
	8.8	M 10	200	46,4	27,8	46,4	23,2	22,1	13,2
	8.8	M 12	240	67,4	40,4	67,4	33,7	32,1	19,2
	8.8	M 16	320	125,0	75,0	125,0	62,5	59,5	35,7
	8.8	M 20	400	203,0	121,8	203,0	101,5	96,6	58,0
	8.8	M 24	480	293,0	175,8	293,0	146,5	139,5	83,7
	8.8	M 27	540	381,0	228,6	381,0	190,5	181,4	108,8
	8.8	M 30	600	466,0	279,6	466,0	233,0	221,9	133,1



SCHEDA TECNICA TECHNICAL DATA SHEET FICHE TECHNIQUE TECHNISCHES DATENBLATT

> Dati carico > Load data > Données de charge > Lastdaten

D E N G E L	N_{rum} [kN]	Carico ultimo medio a trazione > Average ultimate tension load > Charge maximum moyenne de traction Durchschnittliche maximale Zuglast
	V_{rum} [kN]	Carico ultimo medio a taglio > Average ultimate shear load > Charge maximum moyenne de cisaillement Durchschnittliche maximale Querlast
	N_{rk} [kN]	Carico caratteristico a trazione > Characteristic tension load > Charge caracteristique de traction Charakteristische Zuglast
	V_{rk} [kN]	Carico caratteristico a taglio > Characteristic shear load > Charge caracteristique de cisaillement Charakteristische Querlast
	N_{rec} [kN]	Carico ammissibile a trazione > Admissible tensile load > Charge admissible de traction > Zulässige Zuglast
	V_{rec} [kN]	Carico ammissibile a taglio > Admissible shear load > Charge admissible de cisaillement > Zulässige Querlast

> Carichi validi per singolo ancorante senza influenza di interasse e distanza dal bordo e $h \geq 2h_{ef}$
 > Loads for single anchor with no influence of spacing and edge distance and with $h \geq 2h_{ef}$
 > Charges valables pour chaque ancrage sans influence d'interaxe et distance du bord et $h \geq 2h_{ef}$
 > Passende Ringe für den einzelnen Veranker, ohne Achsenabstandseinfluss und des Randabstands und $h \geq 2h_{ef}$

> Azione di taglio non diretta verso il bordo > Coefficiente di sicurezza globale incluso > Coefficiente lato carichi utilizzato = 1,4
 > Shear directed away from the edge > General safety factor included > Load increasing safety coefficient used = 1,4
 > Action de cisaillement pas dirigée vers le bord > Coefficient de sécurité generale inclu > Coefficient côté charge utilisé = 1,4
 > Queraktion nicht an den Rand gerichtet > Generelle Sicherheitskoeffizient inbegriffen > Verwendeter Lasterhöhungssicherheitskoeffizient = 1,4

> 1kN = 100 Kg

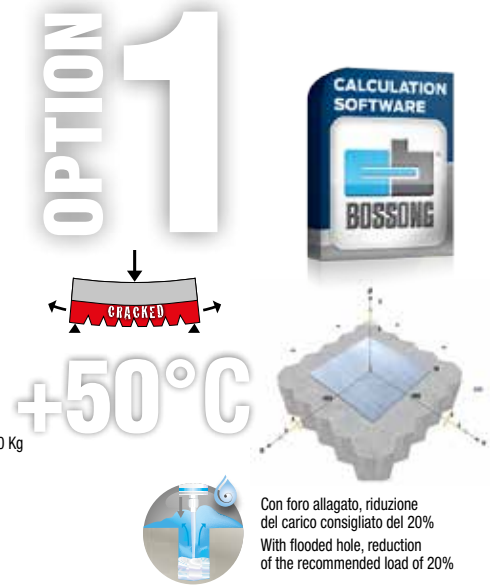

Con foro allagato, riduzione del carico consigliato del 20%
 With flooded hole, reduction of the recommended load of 20%

MIN Dati di carico con profondità effettiva ancoraggio MINIMA > Load data with MINIMUM effective anchorage depth Données de charge avec profondeur efficace d'ancrage MINIMALE > Lastdaten mit MINIMUM effektive Verankerungstiefe

MATERIALE MATERIAL	BARRA ROD	DIAMETRO BARRA ROD DIAMETER	PROFONDITÀ EFF. ANCORAGGIO EFFECTIVE ANCHORAGE DEPTH	CARICO ULTIMO MEDIO A TRAZIONE ULTIMATE TENSION LOAD	CARICO ULTIMO MEDIO A TAGLIO ULTIMATE SHEAR LOAD	CARICO CARATTERISTICO A TRAZIONE CHARACTERISTIC TENSILE LOAD	CARICO CARATTERISTICO A TAGLIO CHARACTERISTIC SHEAR LOAD	CARICO AMMISSIBILE A TRAZIONE ADMISSIBLE TENSILE LOAD	CARICO AMMISSIBILE A TAGLIO ADMISSIBLE SHEAR LOAD
			$h_{ef MIN}$ [mm]	N_{rum} [kN]	V_{rum} [kN]	N_{rk} [kN]	V_{rk} [kN]	N_{rec} [kN]	V_{rec} [kN]
EPOXY 21 C20/25 Calcestruzzo fessurato Cracked Concrete Beton fissuré Gerissener Beton 	≥ 5.8	M 12	70	27,8	26,2	15,8	21,9	7,5	12,5
		M 16	80	33,9	48,9	20,8	40,8	9,9	19,8
		M 20	90	40,5	76,2	30,7	61,5	14,6	29,2
		M 24	96	44,6	89,3	33,8	67,7	16,2	32,2

MED Dati di carico con profondità effettiva ancoraggio MEDIA > Load data with MEDIUM effective anchorage depth Données de charge avec profondeur efficace d'ancrage MOYENNE > Lastdaten mit MITTEL effektive Verankerungstiefe

MATERIALE MATERIAL	BARRA ROD	DIAMETRO BARRA ROD DIAMETER	PROFONDITÀ EFF. ANCORAGGIO EFFECTIVE ANCHORAGE DEPTH	CARICO ULTIMO MEDIO A TRAZIONE ULTIMATE TENSION LOAD	CARICO ULTIMO MEDIO A TAGLIO ULTIMATE SHEAR LOAD	CARICO CARATTERISTICO A TRAZIONE CHARACTERISTIC TENSILE LOAD	CARICO CARATTERISTICO A TAGLIO CHARACTERISTIC SHEAR LOAD	CARICO AMMISSIBILE A TRAZIONE ADMISSIBLE TENSILE LOAD	CARICO AMMISSIBILE A TAGLIO ADMISSIBLE SHEAR LOAD
			$h_{ef MED}$ [mm]	N_{rum} [kN]	V_{rum} [kN]	N_{rk} [kN]	V_{rk} [kN]	N_{rec} [kN]	V_{rec} [kN]
EPOXY 21 C20/25 Calcestruzzo fessurato Cracked Concrete Beton fissuré Gerissener Beton 	≥ 5.8	M 12	110	43,8	26,2	24,8	21,9	11,8	12,5
		M 16	125	66,3	48,9	32,6	40,8	15,5	23,3
		M 20	170	105,2	76,2	60,7	63,5	28,9	36,2
		M 24	210	144,5	110,4	92,0	92,0	43,8	52,5

MAX Dati di carico con profondità effettiva ancoraggio MASSIMO > Load data with MAXIMUM effective anchorage depth Données de charge avec profondeur efficace d'ancrage MAXIMUM > Lastdaten mit MAXIMUM effektive Verankerungstiefe

MATERIALE MATERIAL	BARRA ROD	DIAMETRO BARRA ROD DIAMETER	PROFONDITÀ EFF. ANCORAGGIO EFFECTIVE ANCHORAGE DEPTH	CARICO ULTIMO MEDIO A TRAZIONE ULTIMATE TENSION LOAD	CARICO ULTIMO MEDIO A TAGLIO ULTIMATE SHEAR LOAD	CARICO CARATTERISTICO A TRAZIONE CHARACTERISTIC TENSILE LOAD	CARICO CARATTERISTICO A TAGLIO CHARACTERISTIC SHEAR LOAD	CARICO AMMISSIBILE A TRAZIONE ADMISSIBLE TENSILE LOAD	CARICO AMMISSIBILE A TAGLIO ADMISSIBLE SHEAR LOAD
			$h_{ef MAX}$ [mm]	N_{rum} [kN]	V_{rum} [kN]	N_{rk} [kN]	V_{rk} [kN]	N_{rec} [kN]	V_{rec} [kN]
EPOXY 21 C20/25 Calcestruzzo fessurato Cracked Concrete Beton fissuré Gerissener Beton 	8.8	M 12	240	67,4	40,4	54,2	33,7	25,8	19,2
		M 16	320	125,0	75,0	83,5	62,5	39,7	35,7
		M 20	400	203,0	121,8	143,0	101,5	68,1	58,0
		M 24	480	293,0	175,8	210,3	146,5	100,1	83,7



> **Dati carico > Load data > Données de charge > Lastdaten**

LEGENDA	N_{rum} [kN]	Carico ultimo medio a trazione > Average ultimate tension load > Charge maximum moyenne de traction Durchschnittliche maximale Zuglast
	V_{rum} [kN]	Carico ultimo medio a taglio > Average ultimate shear load > Charge maximum moyenne de cisaillement Durchschnittliche maximale Querlast
	N_{rk} [kN]	Carico caratteristico a trazione > Characteristic tension load > Charge caractéristique de traction Charakteristische Zuglast
	V_{rk} [kN]	Carico caratteristico a taglio > Characteristic shear load > Charge caractéristique de cisaillement Charakteristische Querlast
	N_{rec} [kN]	Carico ammissibile a trazione > Admissible tensile load > Charge admissible de traction > Zulässige Zuglast
	V_{rec} [kN]	Carico ammissibile a taglio > Admissible shear load > Charge admissible de cisaillement > Zulässige Querlast

> Carichi validi per singolo ancorante senza influenza di interasse e distanza dal bordo e $h \geq 2h_{ef}$
> Loads for single anchor with no influence of spacing and edge distance and with $h \geq 2h_{ef}$
> Charges valables pour chaque ancrage sans influence d'interaxe et distance du bord et $h \geq 2h_{ef}$
> Passende Ringe für den einzelnen Veranker, ohne Achsenabstandseinfluss und des Randabstands und $h \geq 2h_{ef}$

> 1kN = 100 Kg

> Azione di taglio non diretta verso il bordo
> Shear directed away from the edge
> Action de cisaillement pas dirigée vers le bord
> Queraktion nicht an den Rand gerichtet

> Coefficiente di sicurezza globale incluso
> General safety factor included
> Coefficient de sécurité générale inclu
> Generelle Sicherheitskoeffizient inbegriffen

> Coefficiente lato carichi utilizzato = 1,4
> Load increasing safety coefficient used = 1,4
> Coefficient côté charge utilisé = 1,4
> Verwendeter Lasterhöhungssicherheitskoeffizient = 1,4

OPTION 7
+50°C

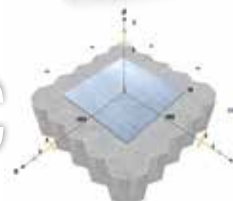
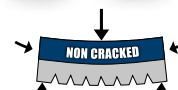

Con foro allagato, riduzione del carico consigliato del 20%
With flooded hole, reduction of the recommended load of 20%

MIN Dati di carico con profondità effettiva ancoraggio MINIMA > Load data with MINIMUM effective anchorage depth
Donnes de charge avec profondeur efficace d'ancrage MINIMALE > Lastdaten mit MINIMUM effektive Verankerungstiefe

MATERIALE MATERIAL	BARRA ROD	DIAMETRO BARRA ROD DIAMETER	PROFONDITÀ EFF. ANCORAGGIO EFFECTIVE ANCHORAGE DEPTH	CARICO ULTIMO MEDIO A TRAZIONE ULTIMATE TENSION LOAD	CARICO ULTIMO MEDIO A TAGLIO ULTIMATE SHEAR LOAD	CARICO CARATTERISTICO A TRAZIONE CHARACTERISTIC TENSILE LOAD	CARICO CARATTERISTICO A TAGLIO CHARACTERISTIC SHEAR LOAD	CARICO AMMISSIBILE A TRAZIONE ADMISSIBLE TENSILE LOAD	CARICO AMMISSIBILE A TAGLIO ADMISSIBLE SHEAR LOAD	
			d [mm]	$h_{ef MIN}$ [mm]	N_{rum} [kN]	V_{rum} [kN]	N_{rk} [kN]	V_{rk} [kN]	N_{rec} [kN]	V_{rec} [kN]
C20/25 Calcestruzzo non fessurato Non cracked Concrete Beton non fissuré Ungerissener Beton		≥ 5.8	≥ 5.8	M 8	19,0	11,4	13,5	9,5	6,4	5,4
			≥ 5.8	M 10	25,4	18,1	15,8	15,1	7,5	8,6
			≥ 5.8	M 12	39,4	26,2	22,2	21,9	10,5	12,5
			≥ 5.8	M 16	48,3	48,9	35,4	40,8	16,8	23,3
			≥ 5.8	M 20	57,6	76,2	41,5	63,5	19,7	36,2
			≥ 5.8	M 24	63,4	110,4	47,5	92,0	22,6	45,2
			≥ 5.8	M 27	77,8	143,4	58,2	116,5	27,7	55,4
			≥ 5.8	M 30	88,7	175,2	66,3	132,8	31,6	63,2

MED Dati di carico con profondità effettiva ancoraggio MEDIA > Load data with MEDIUM effective anchorage depth
Donnes de charge avec profondeur efficace d'ancrage MOYENNE > Lastdaten mit MITTEL effektive Verankerungstiefe

MATERIALE MATERIAL	BARRA ROD	DIAMETRO BARRA ROD DIAMETER	PROFONDITÀ EFF. ANCORAGGIO EFFECTIVE ANCHORAGE DEPTH	CARICO ULTIMO MEDIO A TRAZIONE ULTIMATE TENSION LOAD	CARICO ULTIMO MEDIO A TAGLIO ULTIMATE SHEAR LOAD	CARICO CARATTERISTICO A TRAZIONE CHARACTERISTIC TENSILE LOAD	CARICO CARATTERISTICO A TAGLIO CHARACTERISTIC SHEAR LOAD	CARICO AMMISSIBILE A TRAZIONE ADMISSIBLE TENSILE LOAD	CARICO AMMISSIBILE A TAGLIO ADMISSIBLE SHEAR LOAD	
			d [mm]	$h_{ef MED}$ [mm]	N_{rum} [kN]	V_{rum} [kN]	N_{rk} [kN]	V_{rk} [kN]	N_{rec} [kN]	V_{rec} [kN]
C20/25 Calcestruzzo non fessurato Non cracked Concrete Beton non fissuré Ungerissener Beton		≥ 5.8	≥ 5.8	M 8	19,0	11,4	18,0	9,5	8,6	5,4
			≥ 5.8	M 10	30,2	18,1	23,8	15,1	11,3	8,6
			≥ 5.8	M 12	43,8	26,2	34,9	21,9	16,6	12,5
			≥ 5.8	M 16	81,6	48,9	55,3	40,8	26,3	23,3
			≥ 5.8	M 20	127,0	76,2	78,4	63,5	37,3	36,2
			≥ 5.8	M 24	184,0	110,4	142,8	92,0	68,0	52,5
			≥ 5.8	M 27	239,0	143,4	182,2	119,5	86,8	68,2
			≥ 5.8	M 30	292,0	175,2	211,5	146,0	100,7	83,4

MAX Dati di carico con profondità effettiva ancoraggio MASSIMO > Load data with MAXIMUM effective anchorage depth
Donnes de charge avec profondeur efficace d'ancrage MAXIMUM > Lastdaten mit MAXIMUM effektive Verankerungstiefe

MATERIALE MATERIAL	BARRA ROD	DIAMETRO BARRA ROD DIAMETER	PROFONDITÀ EFF. ANCORAGGIO EFFECTIVE ANCHORAGE DEPTH	CARICO ULTIMO MEDIO A TRAZIONE ULTIMATE TENSION LOAD	CARICO ULTIMO MEDIO A TAGLIO ULTIMATE SHEAR LOAD	CARICO CARATTERISTICO A TRAZIONE CHARACTERISTIC TENSILE LOAD	CARICO CARATTERISTICO A TAGLIO CHARACTERISTIC SHEAR LOAD	CARICO AMMISSIBILE A TRAZIONE ADMISSIBLE TENSILE LOAD	CARICO AMMISSIBILE A TAGLIO ADMISSIBLE SHEAR LOAD	
			d [mm]	$h_{ef MAX}$ [mm]	N_{rum} [kN]	V_{rum} [kN]	N_{rk} [kN]	V_{rk} [kN]	N_{rec} [kN]	V_{rec} [kN]
C20/25 Calcestruzzo non fessurato Non cracked Concrete Beton non fissuré Ungerissener Beton		8.8	8.8	M 8	29,2	17,5	29,2	14,6	13,9	8,3
			8.8	M 10	46,4	27,8	46,4	23,2	22,1	13,2
			8.8	M 12	67,4	40,4	67,4	33,7	32,1	19,2
			8.8	M 16	125,0	75,0	125,0	62,5	59,5	35,7
			8.8	M 20	203,0	121,8	184,6	101,5	87,9	58,0
			8.8	M 24	293,0	175,8	293,0	146,5	139,5	83,7
			8.8	M 27	381,0	228,6	381,0	190,5	181,4	108,8
			8.8	M 30	466,0	279,6	466,0	233,0	221,9	133,1





SCHEDA TECNICA TECHNICAL DATA SHEET FICHE TECHNIQUE TECHNISCHES DATENBLATT



Perforazione con trapano > Hammer drilled holes
Perçage avec perforateur > Durchbohrung mit Bohrmaschine



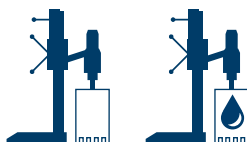

MATERIALE MATERIAL	TIPOLOGIA DI BARRA TYPE OF ROD	DIAMETRO BARRA ROD DIAMETER	TENSIONE DI ADERENZA fbd [N/mm ²] > BOND RESISTANCE fbd [N/mm ²] Buone condizioni di aderenza > Good bond condition								
			d [mm]	C 12/15	C 16/20	C 20/25	C 25/30	C 30/37	C 35/45	C 40/50	C 45/55
Calcestruzzo Concrete Beton Beton  ETAG 001 TR023 ETA-11/0345  (*) Rebar = B450C; BST 500	Rebar (*)	Ø 8	1,6	2,0	2,3	2,7	3,0	3,4	3,7	4,0	4,3
	Rebar (*)	Ø 10	1,6	2,0	2,3	2,7	3,0	3,4	3,7	4,0	4,3
	Rebar (*)	Ø 12	1,6	2,0	2,3	2,7	3,0	3,4	3,7	4,0	4,3
	Rebar (*)	Ø 14	1,6	2,0	2,3	2,7	3,0	3,4	3,7	4,0	4,3
	Rebar (*)	Ø 16	1,6	2,0	2,3	2,7	3,0	3,4	3,7	4,0	4,3
	Rebar (*)	Ø 20	1,6	2,0	2,3	2,7	3,0	3,4	3,7	4,0	4,3
	Rebar (*)	Ø 25	1,6	2,0	2,3	2,7	3,0	3,4	3,7	4,0	4,3
	Rebar (*)	Ø 28	1,6	2,0	2,3	2,7	3,0	3,4	3,7	4,0	4,3
	Rebar (*)	Ø 32	1,6	2,0	2,3	2,7	3,0	3,4	3,7	4,0	4,0

Dati di tensione di aderenza fbd validi per tutte le lunghezze di ancoraggio > Design value of bond strength fbd suitable for all anchorage lengths
Donnés de tension et d'adhérence fbd valables pour toutes les longueurs d'ancrage > Bemessungswert der Verbundspannung fbd Gültig für alle Ankerungslänge



Perforazione con carotatrice (secco/umido)
Drilling with core-drill (dry/wet)
Perçage avec machine pour carottage (sec/humide)
Durchbohrung mit Kernbohrmotor (nass/trocken)



MATERIALE MATERIAL	TIPOLOGIA DI BARRA TYPE OF ROD	DIAMETRO BARRA ROD DIAMETER	TENSIONE DI ADERENZA fbd [N/mm ²] > BOND RESISTANCE fbd [N/mm ²] Buone condizioni di aderenza > Good bond condition								
			d [mm]	C 12/15	C 16/20	C 20/25	C 25/30	C 30/37	C 35/45	C 40/50	C 45/55
Calcestruzzo Concrete Beton Beton  ETAG 001 TR023 ETA-11/0345  (*) Rebar = B450C; BST 500	Rebar (*)	Ø 8	1,6	2,0	2,3	2,7	3,0	3,4	3,7	4,0	4,3
	Rebar (*)	Ø 10	1,6	2,0	2,3	2,7	3,0	3,4	3,7	4,0	4,3
	Rebar (*)	Ø 12	1,6	2,0	2,3	2,7	3,0	3,4	3,7	4,0	4,3
	Rebar (*)	Ø 14	1,6	2,0	2,3	2,7	3,0	3,4	3,7	4,0	4,3
	Rebar (*)	Ø 16	1,6	2,0	2,3	2,7	3,0	3,4	3,7	4,0	4,3
	Rebar (*)	Ø 20	1,6	2,0	2,3	2,7	3,0	3,4	3,7	4,0	4,3
	Rebar (*)	Ø 25	1,6	2,0	2,3	2,7	3,0	3,4	3,7	4,0	4,3
	Rebar (*)	Ø 28	1,6	2,0	2,3	2,7	3,0	3,4	3,7	3,7	3,7
	Rebar (*)	Ø 32	1,6	2,0	2,3	2,7	3,0	3,0	3,0	3,0	3,0

Dati di tensione di aderenza fbd validi per tutte le lunghezze di ancoraggio > Design value of bond strength fbd suitable for all anchorage lengths
Donnés de tension et d'adhérence fbd valables pour toutes les longueurs d'ancrage > Bemessungswert der Verbundspannung fbd Gültig für alle Ankerungslänge



REBAR EC2

REBAR EC2



> **Dati carico > Load data > Données de charge > Lastdaten**

D N E G L	N_{ult} [kN]	Carico ultimo medio a trazione > Average ultimate tension load > Charge maximum moyenne de traction Durchschnittliche maximale Zuglast
	V_{ult} [kN]	Carico ultimo medio a taglio > Average ultimate shear load > Charge maximum moyenne de cisaillement Durchschnittliche maximale Querlast
	N_{ch} [kN]	Carico caratteristico a trazione > Characteristic tension load > Charge caractéristique de traction Caratteristiche Zuglast
	V_{ch} [kN]	Carico caratteristico a taglio > Characteristic shear load > Charge caractéristique de cisaillement Caratteristiche Querlast
	N_{rec} [kN]	Carico ammissibile a trazione > Admissible tensile load > Charge admissible de traction > Zulässige Zuglast
	V_{rec} [kN]	Carico ammissibile a taglio > Admissible shear load > Charge admissible de cisaillement > Zulässige Querlast

- > Applicazioni in accordo alla teoria dell'ancoraggio
- > Application according to the anchors theory
- > Application en conformité avec la théorie de l'ancrage
- > Anwendung in Übereinstimmung mit der Verankerungstheorie

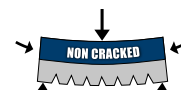

+24°C

- > Carichi validi per singolo ancorante senza influenza di interasse e distanza dal bordo e $h \geq 2h_{ef}$ > 1kN = 100 Kg
- > Loads for single anchor with no influence of spacing and edge distance and with $h \geq 2h_{ef}$
- > Charges valables pour chaque ancrage sans influence d'interaxe et distance du bord et $h \geq 2h_{ef}$
- > Passende Ringe für den einzelnen Veranker, ohne Achsenabstandseinfluss und des Randabstands und $h \geq 2h_{ef}$

- > Azione di taglio non diretta verso il bordo > Coefficiente di sicurezza globale incluso > Coefficiente lato carichi utilizzato = 1,4
- > Shear directed away from the edge > General safety factor included > Load increasing safety coefficient used = 1,4
- > Action de cisaillement pas dirigée vers le bord > Coefficient de sécurité générale inclu > Coefficient côté charge utilisé = 1,4
- > Queraktion nicht an den Rand gerichtet > Generelle Sicherheitskoeffizient einbezogen > Verwendeter Lasterhöhungssicherheitskoeffizient = 1,4



Con foro allagato, riduzione del carico consigliato del 20%
With flooded hole, reduction of the recommended load of 20%

MIN Dati di carico con profondità effettiva ancoraggio MINIMA > Load data with MINIMUM effective anchorage depth
Donnes de charge avec profondeur efficace d'ancrage MINIMALE > Lastdaten mit MINIMALER effektiven Verankerungstiefe

MATERIALE MATERIAL	DIAMETRO BARRA ROD DIAMETER	PROFONDITÀ EFF. ANCORAGGIO EFFECTIVE ANCHORAGE DEPTH	CARICO ULTIMO MEDIO A TRAZIONE	CARICO ULTIMO MEDIO A TAGLIO	CARICO CARATTERISTICO A TRAZIONE	CARICO CARATTERISTICO A TAGLIO	CARICO AMMISSIBILE A TRAZIONE	CARICO AMMISSIBILE A TAGLIO
			ULTIMATE TENSION LOAD	ULTIMATE SHEAR LOAD	CHARACTERISTIC TENSILE LOAD	CHARACTERISTIC SHEAR LOAD	ADMISSIBLE TENSILE LOAD	ADMISSIBLE SHEAR LOAD
EPOXY 2	d [mm]	$h_{ef MIN}$ [mm]	N_{ult} [kN]	V_{ult} [kN]	N_{ch} [kN]	V_{ch} [kN]	N_{rec} [kN]	V_{rec} [kN]
C20/25 Calcestruzzo non fessurato Non cracked Concrete Beton non fissuré Ungerissener Beton	Ø8	60	24,3	16,2	19,8	13,5	9,4	7,7
	Ø10	60	30,4	25,4	23,4	21,2	11,1	12,1
	Ø12	70	39,5	36,6	29,5	30,5	14,0	17,4
	Ø14	80	48,3	49,8	36,1	41,5	17,2	23,7
	Ø16	80	48,3	65,1	36,1	54,2	17,2	31,0
	Ø20	90	57,6	101,7	43,1	84,8	20,5	41,0
	Ø25	100	67,5	135,0	50,5	101,0	24,0	48,1
	Ø28	112	80,0	160,0	59,8	119,7	28,5	57,0
	Ø32	128	97,7	195,5	73,1	146,2	34,8	69,6



MED Dati di carico con profondità effettiva ancoraggio MEDIA > Load data with MEDIUM effective anchorage depth
Donnes de charge avec profondeur efficace d'ancrage MOYENNE > Lastdaten mit MITTLERER effektiven Verankerungstiefe

MATERIALE MATERIAL	DIAMETRO BARRA ROD DIAMETER	PROFONDITÀ EFF. ANCORAGGIO EFFECTIVE ANCHORAGE DEPTH	CARICO ULTIMO MEDIO A TRAZIONE	CARICO ULTIMO MEDIO A TAGLIO	CARICO CARATTERISTICO A TRAZIONE	CARICO CARATTERISTICO A TAGLIO	CARICO AMMISSIBILE A TRAZIONE	CARICO AMMISSIBILE A TAGLIO
			ULTIMATE TENSION LOAD	ULTIMATE SHEAR LOAD	CHARACTERISTIC TENSILE LOAD	CHARACTERISTIC SHEAR LOAD	ADMISSIBLE TENSILE LOAD	ADMISSIBLE SHEAR LOAD
EPOXY 2	d [mm]	$h_{ef MED}$ [mm]	N_{ult} [kN]	V_{ult} [kN]	N_{ch} [kN]	V_{ch} [kN]	N_{rec} [kN]	V_{rec} [kN]
C20/25 Calcestruzzo non fessurato Non cracked Concrete Beton non fissuré Ungerissener Beton	Ø8	80	27,1	16,2	26,4	13,5	12,5	7,7
	Ø10	90	42,4	25,4	37,1	21,2	17,6	12,1
	Ø12	110	61,0	36,6	54,4	30,5	25,9	17,4
	Ø14	125	83,1	49,8	70,5	41,5	33,6	23,7
	Ø16	140	108,5	65,1	75,0	54,2	35,7	31,0
	Ø20	170	149,6	101,7	110,5	84,8	52,6	48,4
	Ø25	210	205,4	159,0	153,6	132,5	73,1	75,7
	Ø28	270	299,4	199,5	216,2	166,2	102,9	95,0
	Ø32	300	350,7	260,5	240,3	217,1	114,4	124,0



MAX Dati di carico con profondità effettiva ancoraggio MASSIMO > Load data with MAXIMUM effective anchorage depth
Donnes de charge avec profondeur efficace d'ancrage MAXIMUM > Lastdaten mit MAXIMALER effektiven Verankerungstiefe

MATERIALE MATERIAL	DIAMETRO BARRA ROD DIAMETER	PROFONDITÀ EFF. ANCORAGGIO EFFECTIVE ANCHORAGE DEPTH	CARICO ULTIMO MEDIO A TRAZIONE	CARICO ULTIMO MEDIO A TAGLIO	CARICO CARATTERISTICO A TRAZIONE	CARICO CARATTERISTICO A TAGLIO	CARICO AMMISSIBILE A TRAZIONE	CARICO AMMISSIBILE A TAGLIO
			ULTIMATE TENSION LOAD	ULTIMATE SHEAR LOAD	CHARACTERISTIC TENSILE LOAD	CHARACTERISTIC SHEAR LOAD	ADMISSIBLE TENSILE LOAD	ADMISSIBLE SHEAR LOAD
EPOXY 2	d [mm]	$h_{ef MAX}$ [mm]	N_{ult} [kN]	V_{ult} [kN]	N_{ch} [kN]	V_{ch} [kN]	N_{rec} [kN]	V_{rec} [kN]
C20/25 Calcestruzzo non fessurato Non cracked Concrete Beton non fissuré Ungerissener Beton	Ø8	160	27,1	16,2	27,1	13,5	12,9	7,7
	Ø10	200	42,4	25,4	42,4	21,2	20,2	12,1
	Ø12	240	61,0	36,6	61,0	30,5	29,0	17,4
	Ø14	280	83,1	49,8	83,1	41,5	39,5	23,7
	Ø16	320	108,5	65,1	108,5	54,2	51,7	31,0
	Ø20	400	169,6	101,7	169,6	84,8	80,7	48,4
	Ø25	500	265,0	159,0	265,0	132,5	126,2	75,7
	Ø28	560	332,5	199,5	332,5	166,2	158,3	95,0
	Ø32	640	434,2	260,5	434,2	217,1	206,8	124,0





SCHEDA TECNICA TECHNICAL DATA SHEET FICHE TECHNIQUE TECHNISCHES DATENBLATT

> Dati carico > Load data > Données de charge > Lastdaten

D	N_{rum} [kN]	Carico ultimo medio a trazione > Average ultimate tension load > Charge maximum moyenne de traction Durchschnittliche maximale Zuglast
	V_{rum} [kN]	Carico ultimo medio a taglio > Average ultimate shear load > Charge maximum moyenne de cisaillement Durchschnittliche maximale Querlast
E	N_{rk} [kN]	Carico caratteristico a trazione > Characteristic tension load > Charge caracteristique de traction Caratteristiche Zuglast
	V_{rk} [kN]	Carico caratteristico a taglio > Characteristic shear load > Charge caracteristique de cisaillement Caratteristiche Querlast
L	N_{rec} [kN]	Carico ammissibile a trazione > Admissible tensile load > Charge admissible de traction > Zulässige Zuglast
	V_{rec} [kN]	Carico ammissibile a taglio > Admissible shear load > Charge admissible de cisaillement > Zulässige Querlast

- > Applicazioni in accordo alla teoria dell'ancoraggio
- > Application according to the anchors theory
- > Application en conformité avec la théorie de l'ancrage
- > Anwendung in Übereinstimmung mit der Verankerungstheorie

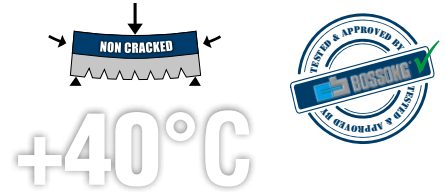

- > Carichi validi per singolo ancorante senza influenza di interasse e distanza dal bordo e $h \geq 2h_{ef}$ > 1kN = 100 Kg
- > Loads for single anchor with no influence of spacing and edge distance and with $h \geq 2h_{ef}$
- > Charges valables pour chaque ancrage sans influence d'interaxe et distance du bord et $h \geq 2h_{ef}$
- > Passende Ringe für den einzelnen Veranker, ohne Achsenabstandseinfluss und des Randabstands und $h \geq 2h_{ef}$

- > Azione di taglio non diretta verso il bordo > Coefficiente di sicurezza globale incluso > Coefficiente lato carichi utilizzato = 1,4
- > Shear directed away from the edge > General safety factor included > Load increasing safety coefficient used = 1,4
- > Action de cisaillement pas dirigée vers le bord > Coefficient de sécurité generale inclu > Coefficient côté charge utilisé = 1,4
- > Queraktion nicht an den Rand gerichtet > Generelle Sicherheitskoeffizient inbegriffen > Verwendeter Lasterhöhungssicherheitskoeffizient = 1,4



Con foro allagato, riduzione del carico consigliato del 20%
With flooded hole, reduction of the recommended load of 20%

MIN Dati di carico con profondità effettiva ancoraggio MINIMA > Load data with MINIMUM effective anchorage depth Donnes de charge avec profondeur efficace d'ancrage MINIMALE > Lastdaten mit MINIMALER effektiven Verankerungstiefe



MATERIALE MATERIAL	DIAMETRO BARRA ROD DIAMETER	PROFONDITÀ EFF. ANCORAGGIO EFFECTIVE ANCHORAGE DEPTH	CARICO ULTIMO MEDIO A TRAZIONE ULTIMATE TENSION LOAD	CARICO ULTIMO MEDIO A TAGLIO ULTIMATE SHEAR LOAD	CARICO CARATTERISTICO A TRAZIONE CHARACTERISTIC TENSILE LOAD	CARICO CARATTERISTICO A TAGLIO CHARACTERISTIC SHEAR LOAD	CARICO AMMISSIBILE A TRAZIONE ADMISSIBLE TENSILE LOAD	CARICO AMMISSIBILE A TAGLIO ADMISSIBLE SHEAR LOAD
			N_{rum} [kN]	V_{rum} [kN]	N_{rk} [kN]	V_{rk} [kN]	N_{rec} [kN]	V_{rec} [kN]
C20/25 Calcestruzzo non fessurato Non cracked Concrete Beton non fissuré Ungerissener Beton	d [mm]	$h_{ef MIN}$ [mm]						
	Ø8	60	24,3	16,2	14,9	13,5	7,1	7,7
	Ø10	60	30,4	25,4	18,6	21,2	8,8	12,1
	Ø12	70	39,5	36,6	26,1	30,5	12,4	17,4
	Ø14	80	48,3	49,8	34,3	41,5	16,3	23,7
	Ø16	80	48,3	65,1	32,3	54,2	15,3	30,7
	Ø20	90	57,6	101,7	43,1	84,8	20,5	41,0
	Ø25	100	67,5	135,0	50,5	101,0	24,0	48,1
	Ø28	112	80,0	160,0	59,8	119,7	28,5	57,0
	Ø32	128	97,7	195,5	73,1	146,2	34,8	69,6

MED Dati di carico con profondità effettiva ancoraggio MEDIA > Load data with MEDIUM effective anchorage depth Donnes de charge avec profondeur efficace d'ancrage MOYENNE > Lastdaten mit MITTLERER effektiven Verankerungstiefe



MATERIALE MATERIAL	DIAMETRO BARRA ROD DIAMETER	PROFONDITÀ EFF. ANCORAGGIO EFFECTIVE ANCHORAGE DEPTH	CARICO ULTIMO MEDIO A TRAZIONE ULTIMATE TENSION LOAD	CARICO ULTIMO MEDIO A TAGLIO ULTIMATE SHEAR LOAD	CARICO CARATTERISTICO A TRAZIONE CHARACTERISTIC TENSILE LOAD	CARICO CARATTERISTICO A TAGLIO CHARACTERISTIC SHEAR LOAD	CARICO AMMISSIBILE A TRAZIONE ADMISSIBLE TENSILE LOAD	CARICO AMMISSIBILE A TAGLIO ADMISSIBLE SHEAR LOAD
			N_{rum} [kN]	V_{rum} [kN]	N_{rk} [kN]	V_{rk} [kN]	N_{rec} [kN]	V_{rec} [kN]
C20/25 Calcestruzzo non fessurato Non cracked Concrete Beton non fissuré Ungerissener Beton	d [mm]	$h_{ef MED}$ [mm]						
	Ø8	80	27,1	16,2	19,8	13,5	9,4	7,7
	Ø10	90	42,4	25,4	27,9	21,2	13,3	12,1
	Ø12	110	61,0	36,6	41,0	30,5	19,5	17,4
	Ø14	125	83,1	49,8	53,6	41,5	25,5	23,7
	Ø16	140	108,5	65,1	56,5	54,2	26,9	31,0
	Ø20	170	149,6	101,7	83,3	84,8	39,6	48,4
	Ø25	210	205,4	159,0	123,7	132,5	58,9	75,7
	Ø28	270	299,4	199,5	162,9	166,2	77,6	95,0
	Ø32	300	350,7	260,5	181,1	217,1	86,2	124,0

MAX Dati di carico con profondità effettiva ancoraggio MASSIMO > Load data with MAXIMUM effective anchorage depth Donnes de charge avec profondeur efficace d'ancrage MAXIMUM > Lastdaten mit MAXIMALER effektiven Verankerungstiefe



MATERIALE MATERIAL	DIAMETRO BARRA ROD DIAMETER	PROFONDITÀ EFF. ANCORAGGIO EFFECTIVE ANCHORAGE DEPTH	CARICO ULTIMO MEDIO A TRAZIONE ULTIMATE TENSION LOAD	CARICO ULTIMO MEDIO A TAGLIO ULTIMATE SHEAR LOAD	CARICO CARATTERISTICO A TRAZIONE CHARACTERISTIC TENSILE LOAD	CARICO CARATTERISTICO A TAGLIO CHARACTERISTIC SHEAR LOAD	CARICO AMMISSIBILE A TRAZIONE ADMISSIBLE TENSILE LOAD	CARICO AMMISSIBILE A TAGLIO ADMISSIBLE SHEAR LOAD
			N_{rum} [kN]	V_{rum} [kN]	N_{rk} [kN]	V_{rk} [kN]	N_{rec} [kN]	V_{rec} [kN]
C20/25 Calcestruzzo non fessurato Non cracked Concrete Beton non fissuré Ungerissener Beton	d [mm]	$h_{ef MAX}$ [mm]						
	Ø8	160	27,1	16,2	27,1	13,5	12,9	7,7
	Ø10	200	42,4	25,4	42,4	21,2	20,2	12,1
	Ø12	240	61,0	36,6	61,0	30,5	29,0	17,4
	Ø14	280	83,1	49,8	83,1	41,5	39,5	23,7
	Ø16	320	108,5	65,1	108,5	54,2	51,7	31,0
	Ø20	400	169,6	101,7	169,6	84,8	80,7	48,4
	Ø25	500	265,0	159,0	265,0	132,5	126,2	75,7
	Ø28	560	332,5	199,5	332,5	166,2	158,3	95,0
	Ø32	640	434,2	260,5	386,3	217,1	184,0	124,0



> **Dati carico > Load data > Données de charge > Lastdaten**



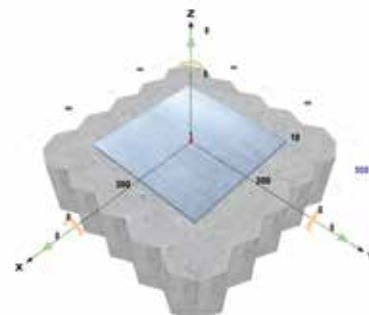

D	Materiale > Material > Matériel > Material
	Tipologia di barra > Type of rod > Barre classe > Stange Klasse
N	d [mm] Diametro barra > Rod diameter > Diamètre de la barre > Stangedurchmesser
E	N _{rum} [kN] Carico ultimo medio a trazione > Average ultimate tension load > Charge maximum moyenne de traction Durchschnittliche maximale Zuglast
	V _{rum} [kN] Carico ultimo medio a taglio > Average ultimate shear load > Charge maximum moyenne de cisaillement Durchschnittliche maximale Querlast
G	N _{rec} [kN] Carico ammissibile a trazione > Admissible tensile load > Charge admissible de traction > Zulässige Zuglast
	V _{rec} [kN] Carico ammissibile a taglio > Admissible shear load > Charge admissible de cisaillement > Zulässige Querlast



- > Carichi validi per singolo ancorante senza influenza di interasse e distanza dal bordo e $h \geq 2h_{ef}$ > 1kN = 100 Kg
- > Loads for single anchor with no influence of spacing and edge distance and with $h \geq 2h_{ef}$
- > Charges valables pour chaque ancrage sans influence d'interaxe et distance du bord et $h \geq 2h_{ef}$
- > Passende Ringe für den einzelnen Veranker, ohne Achsenabstandseinfluss und des Randabstands und $h \geq 2h_{ef}$
- > Azione di taglio non diretta verso il bordo > Coefficiente di sicurezza globale incluso > Coefficiente lato carichi utilizzato = 1,4
- > Shear directed away from the edge > General safety factor included > Load increasing safety coefficient used = 1,4
- > Action de cisaillement pas dirigée vers le bord > Coefficient de sécurité generale inclu > Coefficient côté charge utilisé = 1,4
- > Queraktion nicht an den Rand gerichtet > Generelle Sicherheitskoeffizient inbegriffen > Verwendeter Lasterhöhungssicherheitskoeffizient = 1,4



Con foro allagato, riduzione del carico consigliato del 20%
With flooded hole, reduction of the recommended load of 20%
Avec trou inondé, c'est nécessaire réduire de 20% la charge conseillée
Mit Wasser gefüllten Bohrlöcher ist eine Ermäßigung der Projektlast von 20% notwendig

EPOXY 21 MATERIALE MATERIAL	TIPOLOGIA DI BARRA TYPE OF ROD	DIAMETRO BARRA ROD DIAMETER	CARICO ULTIMO MEDIO A TRAZIONE ULTIMATE TENSION LOAD	CARICO ULTIMO MEDIO A TAGLIO ULTIMATE SHEAR LOAD	CARICO AMMISSIBILE A TRAZIONE ADMISSIBLE TENSILE LOAD	CARICO AMMISSIBILE A TAGLIO ADMISSIBLE SHEAR LOAD
			N _{rum} [kN]	V _{rum} [kN]	N _{rec} [kN]	V _{rec} [kN]
Mattone pieno Solid Brick Brique pleine Vollmauerwerk  ≥ 4.6 / A2-70 / A4-70 	≥ 4.6 A2-70 A4 -70	M8	 > Dati di carico raccomandati per applicazioni su materiali base di medie caratteristiche meccaniche. Vista la varietà dei substrati in muratura e/o legno per applicazioni su supporti differenti da quelli considerati, i valori di carico dovranno essere ricavati tramite opportune prove in situ. > Recommended loads for applications on base materials with medium strength characteristics. For different masonry and/or wood base materials, load values must be obtained with in situ tests.		2,0	3,0
	≥ 4.6 A2-70 A4 -70	M10		2,6	3,4	
	≥ 4.6 A2-70 A4 -70	M12		2,8	3,9	
	≥ 4.6 A2-70 A4 -70	M16		4,0	4,2	
Legno lamellare Laminated Timber Timber Holz  ≥ 4.6 / A2-70 / A4-70 	≥ 4.6 A2-70 A4 -70	M8		3,2		
	≥ 4.6 A2-70 A4 -70	M10		4,2		> Per valori a taglio riferirsi alle istruzioni CNR-DT 206/2007 (7.10.2.3)
	≥ 4.6 A2-70 A4 -70	M12		6,1		> For shear loads refer to CNR-DT 206/2007 (7.10.2.3)
	≥ 4.6 A2-70 A4 -70	M16		10,7		

MASONRY & WOOD



SCHEDA TECNICA TECHNICAL DATA SHEET FICHE TECHNIQUE TECHNISCHES DATENBLATT

> Procedura di installazione > Installation procedure > Procédure d'installation > Installationsverfahren

01

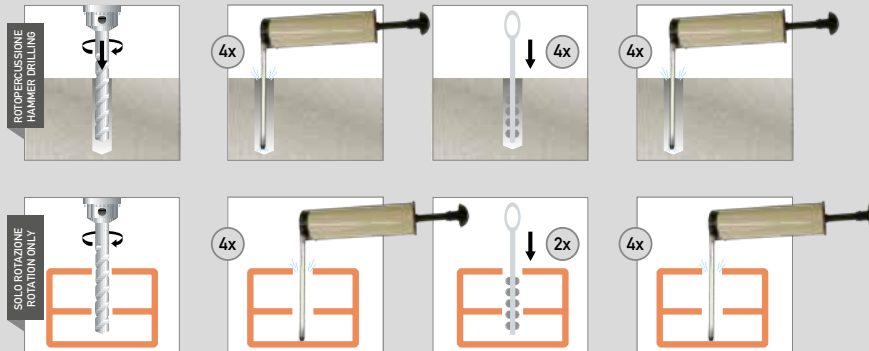

- > Eseguire il foro controllandone la perpendicolarità. Soffiare il foro con apposita pompa soffiante (o aria compressa), eseguire operazione di pulizia della superficie laterale del foro con apposito scovolino metallico, soffiare nuovamente il foro fino a che non fuoriesca più polvere e/o altro materiale residuo. Si raccomanda un'attenta pulizia della superficie laterale del foro con scovolino metallico.
- > Drill the hole and check its perpendicularity. Blow the hole with an appropriate pump blower (or compression air), clean the lateral surface of the hole with an appropriate steel brush, blow again in the hole until there is no dust and/or any residual material inside. We strongly recommend use of the steel brush to clean hole sides.

- > Réaliser le trou en contrôlant la perpendicularité. Souffler dans le trou avec la pompe soufflante prévue (ou de l'air comprimé), effectuer l'opération de nettoyage de la surface latérale du trou avec un écouvillon métallique, souffler à nouveau dans le trou jusqu'à ce qu'il n'en sorte plus de poussière et/ou d'autres matières résiduelles. Nous recommandons l'utilisation d'écouvillon métallique pour le nettoyage de la surface latérale du trou.
- > Stellen Sie die BOHRLOCHUNG unter Kontrolle der Rechtwinkigkeit her. Blasen Sie die BOHRLOCHUNG mit einer entsprechenden Pumpe (oder Druckluft) durch, nehmen Sie eine Reinigung der seitlichen Oberflächen der BOHRLOCHUNG mit einer Bürste von Metall vor, blasen Sie die BOHRLOCHUNG erneut durch, bis kein Pulver und / oder andere Materialrückstände mehr austreten. Insbesondere ist die Benutzung der Metallbürste für die Reinigung der seitlichen Oberfläche der BOHRLOCHUNG notwendig.

02

BCR 300
BCR 165

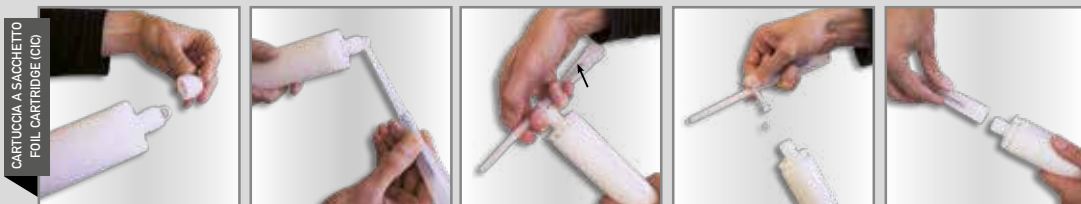

- > Svitare il tappo, avvitare il miscelatore e inserire la cartuccia nella pompa usando protezioni per mani e viso. Nei formati 300 ml e 165 ml svitare il tappo, estrarre la clip metallica secondo le seguenti operazioni:
 - inserire il miscelatore nell'asola dell'estrattore in plastica,
 - tirare l'estrattore per sfilare la clip metallica di chiusura del sacchetto.
 Dopodiché avvitare il miscelatore, inserire la cartuccia nella pompa usando protezioni per mani e viso.
- > Unscrew the front cup, screw on the mixer and insert the cartridge in the gun. Use protections for hands and face. With the size 300 ml and 165 ml, unscrew the front cup, pull-out the steel closing clip according to the following operations:
 - insert the mixer in the eye of the plastic extractor,
 - pull the extractor to unhook the steel closing clip of the foil.
 After that, screw on the mixer and insert the cartridge in the gun. Use protections for hands and face.

- > Dévisser le bouchon, visser le mélangeur et insérer la cartouche dans la pompe en utilisant les protections pour les mains et le visage. Pour les formats 300 ml et 165 ml, dévisser le bouchon, extraire le clip métallique selon les opérations suivantes:
 - insérer le mélangeur dans la fente de l'extracteur en plastique,
 - tirer l'extracteur pour défaire le clip métallique de fermeture du sachet.
 Après cela, visser le mélangeur, insérer la cartouche dans la pompe en utilisant les protections pour les mains et le visage.
- > Lösen Sie den Verschluss, schrauben Sie den Mischer an und bringen Sie den Einsatz in der Pumpe unter Verwendung von Schutzmitteln für Hände und Gesicht an. Lösen Sie bei den Formaten zu 300 ml und 165 ml den Verschluss und ziehen Sie die Metallklemme entsprechend folgender Vorgehensweise heraus:
 - fügen Sie den Mischer in das Langloch der Ausziehvorrichtung aus Kunststoff ein,
 - Ziehen Sie die Ausziehvorrichtung heraus, um die Metallklemme zum Verschließen des Beutels zu entfernen.
 Schrauben Sie dann den Mischer fest und fügen Sie den Einsatz in die Pumpe unter Verwendung von Schutzmitteln für Hände und Gesicht ein.



03



- > Estrudere una prima parte del prodotto assicurandosi che:
 - attraverso il mixer (trasparente) il flusso di prodotto sia composto dalla parte A (colore bianco) e dalla parte B (colore nero).
 - i due componenti si siano completamente miscelati.

La completa miscelazione è raggiunta quando dal miscelatore il prodotto, ottenuto dall'unione dei due componenti, fuoriesce con colore uniforme. Solo allora la cartuccia è pronta per l'uso.
- > Before starting to use the cartridge, eject a first part of the product, being sure that:
 - Through the mixer (transparent) see that the flux of product is compound of the part A (white colour) end of part B (black colour).
 - the two components are completely mixed.

The complete mixing is reached only after that the product, obtained by mixing the two component, comes out from the mixer with an uniform colour. Now the cartridge is ready to be used.

- > Extruder une première partie du produit en s'assurant que:
 - travers le mélangeur (transparent) le flux de produit est composé par les composants A (blanc) et B (noir)
 - les deux composants soient complètement mélangés.

Le mélange complet est atteint quand le produit obtenu par l'union des deux composants sort du mélangeur avec une couleur uniforme. Alors seulement, la cartouche est prête à l'emploi.
- > Ziehen Sie einen ersten Teil des Produktes heraus und prüfen Sie dass:
 - Durch den Mischer (transparent) ist der Fluss des Produktes aus Teil A (weiße Farbe) und Teil B (schwarze Farbe) zusammengesetzt.
 - Die zwei Teilen werden völlig gemischt.

Die komplette Mischung erfolgt als vom Mischer das Produkt, sich ergebend von den zwei Teilen, mit gleichmäßiger Farbe entweicht. Da ist die Kartusche fertig für die Anwendung.

04

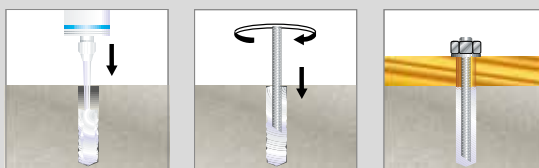

- > 1) Estrudere la resina nel foro fino a riempirlo per 2/3. In caso di materiale forato inserire la gabbietta di plastica e poi estrudere nella gabbietta. 2) Utilizzare una barra filettata tagliata a 45° nell'estremità verso il foro. Prima di inserire la barra verificare che la superficie della stessa sia asciutta, priva di olio ed altri agenti contaminanti. Inserire la barra con un movimento rotatorio per la fuoriuscita delle bolle d'aria. 3) Per l'installazione della barra e la successiva messa in carico rispettare i relativi tempi di posa specificati sia nella scheda tecnica che sull'etichetta del prodotto. 4) Prima della messa in carico verificare l'indurimento del prodotto. 5) La cartuccia può essere riutilizzata successivamente sostituendo il mixer con uno nuovo. Ricordarsi sempre di estrarre una parte del prodotto vedi punto 3.
- > 1) Inject resin into the hole up to fill it 2/3rds. In hollow bricks use the plastic sleeve and inject the resin inside. 2) Use a threaded stud with 45° cut in the side to the hole. Before insert the rod, verify that the element is dry and free oil and other contaminants. Insert threaded stud turning back and forth to avoid presence of air in the fitted hole. 3) For the installation and the following anchor load phase, respect the open time and curing time detailed in the technical data sheet and in the label of the product. 4) Before to load the anchor, check the hardened of the product. 5) The cartridge can be used again screwing the cup and replacing the mixer. Remember to eject a first part of the product, see point 3.

- > 1) Extruder la résine dans le trou jusqu'à le remplir aux 2/3. En cas de matériel troué, insérer la forme en plastique et ensuite extruder dans la forme. 2) Utiliser une barre FILETÉE coupée à 45° à l'extrémité côté trou. Avant d'insérer la barre, vérifier que la surface est sèche, sans rest de huile ou d'autres agents contaminants. Insérer la barre avec un mouvement de rotation pour faire sortir les bulles d'air. 3) Pour l'installation de la barre et le suivant chargement de l'ancrage, respecter les temps de prise indiqués sur la fiche technique et sur la cartouche. 4) Avant de charger l'ancrage, vérifier le durcissement du produit. 5) La cartouche peut être réutilisée par la suite en remplaçant le mixer par un nouveau. Se rappeler de toujours extruder une partie du produit voir point 3.
- > 1) Pressen Sie das Harz in das BOHRLOCH bis diese zu 2/3 gefüllt ist. Bei Lochmaterialien muss der Siebhülse eingefügt und dann in die Hülse gepresst werden. 2) Verwenden Sie einen Gewindestab mit 45°-Schnitt am zur BOHRLOCHUNG zeigenden Ende. Vor dem Einstecken des Gewindestabes prüfen dass seine Fläche trocken, ohne Öl und andere verunreinigende Wirkstoffe ist. Fügen Sie den Stab mit einer Drehbewegung ein, um die Luftblasen austreten zu lassen. 3) Warten Sie die Aushärzeit und Verladungszeit ab, die im technischen Datenblatt und auf dem Etikett des Produktes angegeben sind. 4) Vor der Verladung überprüfen dass das Produkt verhärtet ist. 5) Der Einsatz kann später wiederverwendet werden, indem der Mischer durch einen neuen ersetzt wird. Vergessen Sie nicht, immer einen Teil des Produktes herauszupressen, siehe Punkt 3.

> **NOTA:** Dati tecnici, di installazione e di carico possono essere oggetto di revisione. Per una versione aggiornata consultare le schede tecniche sul sito www.bossong.com o contattare il nostro Ufficio Tecnico.

> **WARNING:** Installation and loads technical data can be modified by us. For update technical data sheet see www.bossong.com or be in contact with our Technical Office.

> **NOTE:** données techniques, d'installation et de charge peuvent être objet de révision. Pour une version mise à jour, consulter les fiches techniques dans le site internet www.bossong.com ou contacter notre Bureau Technique.

> **ANMERKUNG:** technische Daten, Installationsangaben und Lastdaten können modifiziert werden. Für die aktualisierte Version sind die technischen Blätter auf der Webseite www.bossong.com nachzuschauen, oder unser Technisches Büro soll konsultiert werden.