

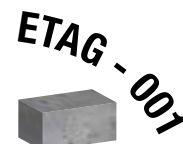

VINIL

Prodotto per uso strutturale in accordo al D.M. 14/01/2008



BCR-400 VINIL

Cartuccia coassiale
 Coaxial cartridge
 Cartouche coaxial
 Koaxialkartusche
 400 ml
cod. 747580



BCR-300 VINIL

Cartuccia sacchetto
 Foil cartridge
 Cartouche avec sachet
 Schlauchfolienkartusche
 300 ml
cod. 747568



BCR-165 VINIL

Cartuccia sacchetto
 Foil cartridge
 Cartouche avec sachet
 Schlauchfolienkartusche
 165 ml
cod. 747558



STOCCAGGIO E CONSERVAZIONE
STORAGE AND CONSERVATION
STOCKAGE ET CONSERVATION
LAGERUNG UND AUFBEWAHRUNG



CARTUCCIA
CARTRIDGE
CARTOUCHE
KARTUSCHE



DURATA (mesi)
EXPIRY (months)
ECHEANCHE (mois)
HALTBARKEIT (Monate)



**SCHEDA TECNICA
TECHNICAL DATA SHEET
FICHE TECHNIQUE
TECHNISCHES DATENBLATT**

VINIL
> CARATTERISTICHE > CHARACTERISTICS
> CARACTÉRISTIQUES > EIGENSCHAFTEN



**Resina Epossiacrilato senza stirene
Epoxy Acrylate resin styrenfree
Résine Epoxy Acrylate sans styrène
Epoxyacrylat-Harz styrolfrei**



Dichiarazione di Prestazione su
Declarations of Performance on
www.bossong.com

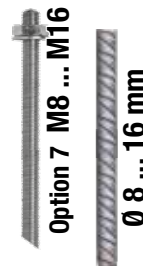

ETA (European Technical Assessment) aggiornati in accordo al nuovo regolamento prodotti da costruzione nr. 305/2011.

ETA-15/0708 Opzione 7 da M8 a M16 per calcestruzzo non fessurato.

Il prodotto è omologato per fissaggi con profondità variabile di ancoraggio, per dare al progettista un'elevata flessibilità. Incremento della massima profondità di ancoraggio fino a venti volte il diametro nominale della barra filettata.

Barre ad aderenza migliorata diametro da 8 mm a 16 mm.

Possibilità di utilizzo del prodotto in calcestruzzo asciutto, umido.

Le temperature di esercizio certificate sono negli intervalli:

-40°C/+40°C (T° max lungo periodo = 24°C)

-40°C/+50°C (T° max lungo periodo = 40°C)

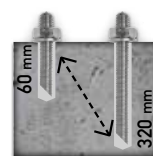

Applicazioni con profondità variabile di ancoraggio
Use with variable anchorage depth
Applications avec variables profondeurs d'ancrage
Anwendungen mit variable Verankerungstiefen



ETA (European Technical Assessments) updated according to the new Construction Product Regulation 305/2011.

ETA-15/0708 Option 7 from M8 to M16 for non-cracked concrete. It is certified for fixing with variable anchorage depths.

This means that the project engineer has with this product a considerable flexibility in the design phase.

Rebar diameter from 8 mm to 16 mm.

Possibility of using the product in dry and wet concrete.

Certified service temperatures are in the ranges:

-40°C/+40°C (T° max long period = 24°C)

-40°C/+50°C (T° max long period = 40°C)



ETA (Évaluations techniques européennes) mises à jour selon le nouveau Règlement sur le Produit de Construction nr. 305/2011.

ETA-15/0708 Option 7 de M8 à M16 pour béton non fissuré. Le produit est homologué pour fixations avec variables profondeurs d'ancrage, pour donner à l'ingénieur une haute flexibilité pendant la phase de projet.

Fers à béton diamètre de 8 mm à 16 mm.

Possibilité d'utilisation du produit en béton sec et humide.

Les températures de travail certifiées sont entre les intervalles:

-40°C/+40°C (T° max longue période = 24°C)

-40°C/+50°C (T° max longue période = 40°C)

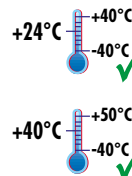

Di esercizio
Service range



ETA (Europäische Technischen Bewertungen) aktualisiert nach der neuen Bauproduktregulierung Nr. 305/2011.

ETA-15/0708 Option 7 für ungerissenen Beton mit Gewindestangen von M8 bis M16. Epoxyacrylat-Harz hat laut CE-ETA variable Verankerungstiefen. So ist der Anwender in hohem Maße flexibel!

Bewehrungsseisen Durchmesser von 8 mm bis zu 16 mm.

Anwendung des Produktes möglich in trockenem und nassem Beton.

Die zugelassene Temperaturbeständigkeit nach Aushärtung liegt zwischen:

-40°C/+40°C (langfristig max. = 24°C)

-40°C/+50°C (langfristig max. = 40°C)

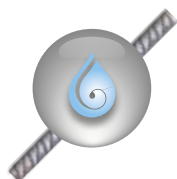

Presenza d'acqua: calcestruzzo umido
Water in place: wet concrete
Eau sur place: béton humide
Wasser in Platz: dieses Harz darf auch in nassem Beton verwendet werden



CARTUCCIA > CARTRIDGE
CARTOUCHE > KARTUSCHE
300 - 165 ml:
Sistema di apertura sacchetto
Plastic foil opening system
Plastic foil opening system
Plastic foil opening system



> Applicazioni > Applications > Applications > Anwendungen



Edilizia Civile Pesante
Heavy Building Construction
Construction Civile Lourde
Schweres Zivilbauwesen



Edilizia Industriale Pesante
Heavy Industrial Construction
Construction industrielle lourde
Schweres Industriebauwesen



Settore Elettrico Pesante
Heavy Electricity Area
Secteur Electricite Lourde
Schweres Elektrischenwesen



Settore Idraulico e Lattineria pesante
Heavy Hydraulic and Tiling Area
Secteur lour Hydroaulique et Ferblanterie
Schweres Hydraulikwesen und
Blecharbeiten

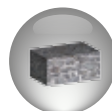

Pietra
Stone
Pierre
Stein



Mattone pieno
Solid Brick
Brique pleine
Vollmauerwerk



Legno
Wood
Bois
Holz

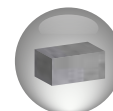

Calcestruzzo
Concrete
Béton
Beton



Mattone forato
Hollow Brick
Brique creux
Lochziegeln

> Gamma prodotti > Product's range > Gamme produits > Warenangebot

	CODICE > CODE NUMBER	ARTICOLO > ITEM TYPE > ARTIKEL	DESCRIZIONE > DESCRIPTION DESCRIPTION > BESCHREIBUNG	 Nr.
	747588	TERMO 165 VINIL	Confezionamento con foglio termico > Thermo foil packed Emballage avec feuil thermique > Thermo- Folienverpackung	12
	747004	KIT 300 VINIL	2 x cartridges, 1 x gun, 4 x mixers, 1x brush, 1 x air pump, 10 x studs M8, 10 x studs M10, 10 x sleeves GC 12x80, 10 x sleeves GC 15x85	1
	747610	KIT 400 VINIL	2 x cartridges, 1 x gun, 4 x mixers, 1x brush, 1 x air pump, 10 x studs M8, 10 x studs M10, 10 x sleeves GC 12x80, 10 x sleeves GC 15x85	1
	747599	OSR 400 VINIL SECCHIO	12 cartucce, 1 pistola, 24 mixer > 12 x cartridges, 1 x gun, 24 x mixers 12 x cartouches, 1 x pompe, 24 x mixers 12 x Kartuschen, 1 x Auspresspistole, 24 x Mischer	1
	747597	OSR 300 VINIL SECCHIO	18 cartucce, 1 pistola, 36 mixer > 18 x cartridges, 1 x gun, 36 x mixers 18 x cartouches, 1 x pompe, 36 x mixers 18 x Kartuschen, 1 x Auspresspistole, 36 x Mischer	1
	747604	OSR 400 VINIL SECCHIO NP-2M	12 cartucce, 24 mixer > 12 x cartridges, 24 x mixers 12 x cartouches, 24 x mixers > 12 x Kartuschen, 24 x Mischer	1
	747602	OSR 300 VINIL SECCHIO NP-2M	18 cartucce, 36 mixer > 18 x cartridges, 36 x mixers 18 x cartouches, 36 x mixers > 18 x Kartuschen, 36 x Mischer	1

CARTUCCIA + MIXER > CARTRIDGE + MIXER
CARTOUCHE + MIXER > KARTUSCHE + MIXER



TEMPI DI POSA
SETTING TIMES
TEMPS D'INSTALLATION
VERLEGUNGSZEIT

°C	01	02	03
30°C	3 min	20 min	
25°C	4 min	30 min	
20°C	6 min	45 min	
10°C	12 min	1 h 30'	
5°C	15 min	2 hours	
0°C	25 min	3 hours	

+5°C

Temperatura minima del prodotto per l'applicazione
Minimum product temperature for application
Température minimal de la cartouche pour l'application
Min Kartouchetemperatur für die Anwendung



- 01 Temperatura supporto > Base material temperature > Temperature material de base > Grundmaterial-temperatur
02 Tempo di lavorabilità > Open time > Temps de manipulation > Verarbeitungszeit
03 Attesa per la messa in carico > Curing time > Temps avant l'application de charge > Bauzeit



SCHEDA TECNICA TECHNICAL DATA SHEET FICHE TECHNIQUE TECHNISCHES DATENBLATT

> Numero fissaggi > Number of fixings > Nombre de fixations > Anzahl der Befestigungen

Fissaggi nei materiali pieni > Fixings in solid materials > Fixations dans matériaux pleins > Befestigungen in vollsteinen



BARRA FILETTATA > THREADED STUD BARRE FILETÉE > GEWINDESTANGE	FORO > HOLE TROU > BOHRLOCH	BCR 165	BCR 300	BCR 400
 d _{nom} [mm]	d _o [mm] x h ₁ [mm]	Nr. Fissaggi > Fixings	Nr. Fissaggi > Fixings	Nr. Fissaggi > Fixings
M 8	10 x 90	± 30	± 54	± 72
M 10	12 x 95	± 21	± 39	± 52
M 12	14 x 115	± 14	± 25	± 34
M 16	18 x 130	± 9	± 16	± 21
M 20	24 x 175	± 3	± 6	± 7
M 24	28 x 215	± 2	± 4	± 5

Fissaggi nei materiali forati > Fixings in hollow materials > Fixations dans matériaux creux > Befestigungen in lochsteinen



BARRA FILETTATA > THREADED STUD BARRE FILETÉE > GEWINDESTANGE	BCR 165	BCR 300	BCR 400	GABBIETTA > SLEEVE TAMIS > HÜLSE
 d _{nom} [mm]	Nr. Fissaggi > Fixings	Nr. Fissaggi > Fixings	Nr. Fissaggi > Fixings	d _{nom} [mm] x L [mm]
M 8	± 15	± 27	± 35	GC 12 x 80
M 8	± 9	± 16	± 21	GC 15 x 85
M 10	± 9	± 16	± 21	GC 15 x 85
M 12	± 9	± 16	± 21	GC 15 x 85
M 12	± 5	± 9	± 12	GC 20 x 85
M 16	± 5	± 9	± 12	GC 20 x 85

- > **NOTE:** Il numero di fissaggi sopra specificato è stato determinato conteggiando esclusivamente il volume teorico di prodotto necessario al riempimento del foro (o gabbietta) escluso il volume della barra inserita. Pur essendo incluso nel calcolo teorico uno spreco standard, il reale quantitativo di prodotto potrà differire da questo in funzione della effettiva modalità di posa in opera adottata.
- > **WARNING:** The number of fixings above mentioned has been calculated according to the theoretical volume needed to fill the hole (or sleeve) excluded the volume of the inserted metal rod. In the theoretical volume it is included a standard extra quantity but the real quantity of the product may be different than it in function of the real application of the product.
- > **NOTE:** Le numéro des fixations sur mentionné a été déterminé en calculant exclusivement le volume théorique de produit nécessaire au remplissage du trou (ou tamis), exclu le volume de la tige filetée. Bien si dans le calcul théorique est incluse une quantité standard de matériel extra, la quantité réelle de produit peut être différente, en fonction des effectives modes d'application du produit.
- > **ANMERKUNG:** Die obengenannte Anzahl der Befestigungen wurde nach dem theoretischen Volumen für die Bohrlochfüllung (oder Siebhülse-Füllung) minus dem Volumen der Gewindestange berechnet. Im theoretischen Volumen wird eine Standard-Extra-Menge einkalkuliert, aber die wirkliche Produktmenge kann anders sein, abhängig von der wirklichen Anwendung des Produktes.



> **Dati installazione > Installation data > Données d'installation > Installationsangaben**

D	Materiale > Material > Matériel > Material
	d [mm] Diametro barra > Rod diameter > Diamètre de la barre > Stangedurchmesser
N	Tipologia di barra > Type of rod > Barre classe > Stange Klasse
	Gabbietta > Plastic sleeve > Tamis > Hülle
E	h _{min} [mm] Spessore minimo del supporto > Minimum thickness of base material Épaisseur Minimal du Matière Base > Mindestbauteildicke
G	d ₀ [mm] Diametro foro > Hole diameter > Diamètre du trou > Bohrlochennendurchmesser
	h ₁ [mm] Profondità del foro > Hole depth > Profondeur du trou > Bohrlochtiefe
L	h _{nom} [mm] Profondità di inserimento > Embedment depth Profondeur d'enfocé > Setztiefe
	h _{ef} [mm] Profondità effettiva ancoraggio > Effective anchorage depth Profondeur efficace d'ancrage > Effektive Verankerungstiefe

D	S _{cr} [mm] Interasse caratteristico > Characteristic spacing Entraxe Caractéristique > Charakteristische Achsabstand
	C _{cr} [mm] Distanza dal bordo caratteristica > Characteristic edge distance Distance du bord caractéristique > Charakteristische Randabstand
N	S _{min} [mm] Interasse minimo > Minimum allowable spacing Entraxe minimale > Minimaler Achsabstand
E	C _{min} [mm] Distanza minima dal bordo > Minimum allowable edge distance Distance du bord minimale > Minimaler Randabstand
G	t _{fix} [mm] Spessore fissabile > Fixture thickness Épaisseur fixable > Anbauteildicke
	d _i [mm] Diametro foro spessore fissabile > Diameter of clearance hole in the fixture Diamètre du trou de épaisseur fixable > Durchgangsloch im Anbauteil
L	S _w [mm] Chiave > Key > Clef > Schlüsselweite
	T _{inst} [Nm] Coppia di serraggio > Installation torque Couple de serrage > Drehmoment Beim Verankern

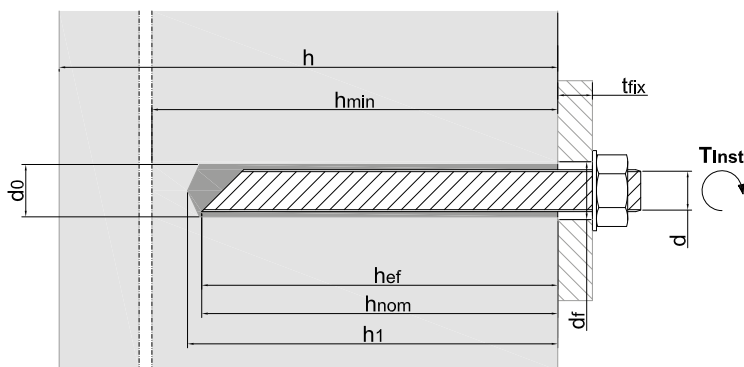

- > **NOTA:** Prima dell'installazione del prodotto consultare la presente sezione e la procedura di installazione completa riportata nelle pagine successive. Si declina ogni responsabilità per l'uso improprio del prodotto.
- > **WARNING:** Before use see this section and the complete procedure of installation reported in the next pages. We assume no liability for the not correct use of the product.
- > **NOTE:** avant l'installation du produit nous vous prions de lire cette section et la procédure d'installation complète que Vous trouvez dans les pages suivantes. Nous n'assumons pas de responsabilité pour une utilisation incorrecte du produit.
- > **ANMERKUNG:** vor der Installation des Produktes bitte diesen Abschnitt und das komplette Installationsverfahren in den folgenden Seiten lesen. Wir übernehmen keine Haftung für die inkorrekte Anwendung des Produktes.



Opzione > Option 7

M8 ... M16



MATERIALE MATERIAL	DIAMETRO BARRA ROD DIAMETER	TIPOLOGIA DI BARRA TYPE OF ROD	SPESSORE MIN. DEL SUPPORTO MIN. THICKNESS BASE MATERIAL			DIAMETRO FORO HOLE DIAMETER	PROFONDITÀ DEL FORO HOLE DEPTH			PROFONDITÀ DI INSERIMENTO EMBEDMENT DEPTH			PROFONDITÀ EFF. ANCORAGGIO EFFECTIVE ANCHORAGE DEPTH			INTERASSE CARATTERISTICO CHARACTERISTIC SPACING			DISTANZA DAL BORDO CARATTERISTICA CHARACTERISTIC EDGE DISTANCE		
			min	med	max		min	med	max	min	med	max	min	med	max	min	med	max	min	med	max
 M8-M16 Calcestruzzo non fessurato Non cracked Concrete	d [mm]		h _{min} [mm]			d ₀ [mm]	h ₁ [mm]			h _{nom} [mm]			h _{ef} [mm]			S _{cr, N} [mm]			C _{cr, N} [mm]		
	M8	≥ 5,8 A4-70	100	110	190	10	65	85	165	60	80	160	60	80	160	180	211	211	90	105	105
	M10	≥ 5,8 A4-70	100	120	230	12	75	95	205	70	90	200	70	90	200	210	263	263	105	132	132
	M12	≥ 5,8 A4-70	110	140	270	14	85	115	245	80	110	240	80	110	240	240	291	291	120	145	145
 M16	M16	≥ 5,8 A4-70	136	161	356	18	105	130	325	100	125	320	100	125	320	300	360	360	150	180	180







SCHEDA TECNICA TECHNICAL DATA SHEET FICHE TECHNIQUE TECHNISCHES DATENBLATT

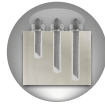

Opzione > Option 7

M8 ... M16



MATERIALE MATERIAL	DIAMETRO BARRA ROD DIAMETER	TIPOLOGIA DI BARRA TYPE OF ROD	INTERASSE MIN. ALLOWABLE SPACING	DISTANZA MIN. DAL BORDO MIN. ALLOWABLE EDGE DISTANCE	SPESS. FISSABILE FIXTURE THICKNESS	DIAMETRO FORO SPESS. FISSABILE DIAMETER OF CLEARANCE HOLE IN THE FIXTURE	CHIAVE KEY	COPIA DI SERRAGGIO INSTALLATION TORQUE
VINIL	d [mm]		S _{min} [mm]	C _{min} [mm]	t _{fix} [mm]	d _r [mm]	S _w [mm]	T _{inst} [Nm]
 M8-M16 Calcestruzzo non fessurato Non cracked Concrete  					min ÷ max			
	M8	≥ 5.8 A4-70	40	40	0 ÷ 1500	9	13	10
	M10	≥ 5.8 A4-70	40	40	0 ÷ 1500	12	17	20
	M12	≥ 5.8 A4-70	40	40	0 ÷ 1500	14	19	40
	M16	≥ 5.8 A4-70	50	50	0 ÷ 1500	18	24	80



- > Per evitare una possibile rottura per splitting, lo spessore del supporto in calcestruzzo dovrà essere $h \geq 2h_{ef}$
- > To avoid splitting failure, the thickness of the concrete member shall be $h \geq 2h_{ef}$
- > Pour éviter une possible rupture par splitting, l'épaisseur du support en béton devrait être $h \geq 2h_{ef}$
- > Um einen splittingbedingten Bruch zu verhindern, die Dicke der Unterlage aus Beton muss $h \geq 2h_{ef}$ sein





Opzione > Option 7



Ø 8 ... 16 mm



MATERIALE MATERIAL	DIAMETRO BARRA ROD DIAMETER	TIPOLOGIA DI BARRA TYPE OF ROD	SPESSORE MIN. DEL SUPPORTO MIN. THICKNESS BASE MATERIAL			DIAMETRO FORO HOLE DIAMETER	PROFONDITÀ DEL FORO HOLE DEPTH			PROFONDITÀ EFF. ANCORAGGIO EFFECTIVE ANCHORAGE DEPTH			INTERASSE CARATTERISTICO CHARACTERISTIC SPACING			DISTANZA DAL BORDO CARATTERISTICA CHARACTERISTIC EDGE DISTANCE			INTERASSE MIN. ALLOWABLE SPACING	DISTANZA MIN. DAL BORDO MIN. ALLOWABLE EDGE DISTANCE
			min	med	max		min	med	max	min	med	max	min	med	max	min	med	max		
 Ø8-Ø16 Calcestruzzo non fessurato Non cracked Concrete  																				
	Ø 8	B450C BST500	100	110	190	12	65	85	165	60	80	160	180	202	202	90	101	101	40	40
	Ø 10	B450C BST500	100	120	230	14	75	95	205	70	90	200	210	242	242	105	121	121	40	40
	Ø 12	B450C BST500	112	142	272	16	85	115	245	80	110	240	240	277	277	120	139	139	40	40
	Ø 14	B450C BST500	116	161	316	18	85	130	285	80	125	280	240	323	323	120	162	162	40	40
	Ø 16	B450C BST500	140	180	360	20	105	145	325	100	125	320	300	351	351	150	175	175	50	50







MATERIALE MATERIAL	DIAMETRO BARRA ROD DIAMETER	TIPOLOGIA DI BARRA TYPE OF ROD	SPESSORE MIN. DEL SUPPORTO MIN. THICKNESS BASE MATERIAL	DIAMETRO FORO HOLE DIAMETER	PROFONDITÀ DEL FORO HOLE DEPTH	PROFONDITÀ DI INSERIMENTO EMBEDMENT DEPTH	PROFONDITÀ EFF. ANCORAGGIO EFFECTIVE ANCHORAGE DEPTH	INTERASSE CARATTERISTICO CHARACTERISTIC SPACING	DISTANZA DAL BORDO CARATTERISTICA CHARACTERISTIC EDGE DISTANCE	INTERASSE MIN. ALLOWABLE SPACING	DISTANZA MIN. DAL BORDO MIN. ALLOWABLE EDGE DISTANCE	SPESS. FISSABILE MAX FIXTURE THICKNESS	DIAMETRO FORO SPESS. FISSABILE DIAMETER OF CLEARANCE HOLE IN THE FIXTURE	CHIAVE KEY	COPPIA DI SERRAGGIO INSTALLATION TORQUE
	d [mm]		h _{min} [mm]	d _o [mm]	h ₁ [mm]	h _{nom} [mm]	h _{ef} [mm]	S _{cz} [mm]	C _{cz} [mm]	S _{min} [mm]	C _{min} [mm]	t _{fix} [mm]	d _r [mm]	S _w [mm]	T _{inst} [Nm]
 Mattone pieno Solid Brick Brique pleine Vollmauerwerk	M8	≥ 4.6 A2-70 A4-70	200	10	85	80	80	160	200	100	100	10	9	13	7
	M10	≥ 4.6 A2-70 A4-70	250	12	90	85	85	200	200	100	100	20	12	17	15
	M12	≥ 4.6 A2-70 A4-70	300	14	100	95	95	240	200	100	100	30	14	19	25
	M16	≥ 4.6 A2-70 A4-70	350	18	130	125	125	320	200	100	100	35	18	24	30

MATERIALE MATERIAL	DIAMETRO BARRA ROD DIAMETER	TIPOLOGIA DI BARRA TYPE OF ROD	GABBIETTA PLASTIC SLEEVE	SPESSORE MIN. DEL SUPPORTO MIN. THICKNESS BASE MATERIAL	DIAMETRO FORO HOLE DIAMETER	PROFONDITÀ DEL FORO HOLE DEPTH	PROFONDITÀ DI INSERIMENTO EMBEDMENT DEPTH	PROFONDITÀ EFF. ANCORAGGIO EFFECTIVE ANCHORAGE DEPTH	INTERASSE CARATTERISTICO CHARACTERISTIC SPACING	DISTANZA DAL BORDO CARATTERISTICA CHARACTERISTIC EDGE DISTANCE	INTERASSE MIN. ALLOWABLE SPACING	DISTANZA MIN. DAL BORDO MIN. ALLOWABLE EDGE DISTANCE	SPESS. FISSABILE MAX FIXTURE THICKNESS	DIAMETRO FORO SPESS. FISSABILE DIAMETER OF CLEARANCE HOLE IN THE FIXTURE	CHIAVE KEY	COPPIA DI SERRAGGIO INSTALLATION TORQUE
	d [mm]		(*)	h _{min} [mm]	d _o [mm]	h ₁ [mm]	h _{nom} [mm]	h _{ef} [mm]	S _{cz} [mm]	C _{cz} [mm]	S _{min} [mm]	C _{min} [mm]	t _{fix} [mm]	d _r [mm]	S _w [mm]	T _{inst} [Nm]
 Mattone forato Hollow Brick Brique creux Lochziegel	M8	≥ 4.6 A2-70 A4-70	GC 15x85	100	16	90	85	85	l _{unit,max}	0,5 x l _{unit,max}	100	100	10	9	13	5
	M10	≥ 4.6 A2-70 A4-70	GC 15x85	100	16	90	85	85	l _{unit,max}	0,5 x l _{unit,max}	100	100	20	12	17	7,5
	M12	≥ 4.6 A2-70 A4-70	GC 15x85	100	16	90	85	85	l _{unit,max}	0,5 x l _{unit,max}	100	100	30	14	19	10

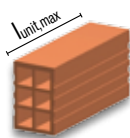
(*) Altre lunghezze disponibili, vedi catalogo > Other lengths available see catalogue

l_{unit,max} = Massima dimensione del blocco di muratura > Max length of masonry unit
Dimension maximale du bloc de maçonnerie > Maximale Größe des Ziegelsteins



MATERIALE MATERIAL	DIAMETRO BARRA ROD DIAMETER	TIPOLOGIA DI BARRA TYPE OF ROD	SPESSORE MIN. DEL SUPPORTO MIN. THICKNESS BASE MATERIAL	DIAMETRO FORO HOLE DIAMETER	PROFONDITÀ DEL FORO HOLE DEPTH	PROFONDITÀ DI INSERIMENTO EMBEDMENT DEPTH	PROFONDITÀ EFF. ANCORAGGIO EFFECTIVE ANCHORAGE DEPTH	INTERASSE CARATTERISTICO CHARACTERISTIC SPACING	DISTANZA DAL BORDO CARATTERISTICA CHARACTERISTIC EDGE DISTANCE	INTERASSE MIN. ALLOWABLE SPACING	DISTANZA MIN. DAL BORDO MIN. ALLOWABLE EDGE DISTANCE	SPESS. FISSABILE MAX FIXTURE THICKNESS	DIAMETRO FORO SPESS. FISSABILE DIAMETER OF CLEARANCE HOLE IN THE FIXTURE	CHIAVE KEY	COPPIA DI SERRAGGIO INSTALLATION TORQUE	
	d [mm]		h _{min} [mm]	d _o [mm]	h ₁ [mm]	h _{nom} [mm]	h _{ef} [mm]	S _{cz} [mm]	C _{cz} [mm]	S _{min} [mm]	C _{min} [mm]	t _{fix} [mm]	d _r [mm]	S _w [mm]	T _{inst} [Nm]	
 Legno lamellare Laminated Timber Holz	M8	≥ 4.6 A2-70 A4-70		160	10	85	80	100	80	50	50	10	9	13	7	
	M10	≥ 4.6 A2-70 A4-70		200	12	105	100	100	125	100	50	50	20	12	17	15
	M12	≥ 4.6 A2-70 A4-70		240	14	125	120	120	150	120	60	60	30	14	19	25
	M16	≥ 4.6 A2-70 A4-70		320	18	165	160	160	200	160	80	80	35	18	24	30



SCHEDA TECNICA TECHNICAL DATA SHEET FICHE TECHNIQUE TECHNISCHES DATENBLATT

> Dati carico > Load data > Données de charge > Lastdaten

D	N_{rum} [kN]	Carico ultimo medio a trazione > Average ultimate tension load > Charge maximum moyenne de traction Durchschnittliche maximale Zuglast
	V_{rum} [kN]	Carico ultimo medio a taglio > Average ultimate shear load > Charge maximum moyenne de cisaillement Durchschnittliche maximale Querlast
E	N_{rk} [kN]	Carico caratteristico a trazione > Characteristic tension load > Charge caractéristique de traction Charakteristische Zuglast
	V_{rk} [kN]	Carico caratteristico a taglio > Characteristic shear load > Charge caractéristique de cisaillement Charakteristische Querlast
L	N_{rec} [kN]	Carico ammissibile a trazione > Admissible tensile load > Charge admissible de traction > Zulässige Zuglast
	V_{rec} [kN]	Carico ammissibile a taglio > Admissible shear load > Charge admissible de cisaillement > Zulässige Querlast

> Carichi validi per singolo ancorante senza influenza di interasse e distanza dal bordo e $h \geq 2h_{ef}$ > 1kN = 100 Kg
> Loads for single anchor with no influence of spacing and edge distance and with $h \geq 2h_{ef}$
> Charges valables pour chaque ancrage sans influence d'interaxe et distance du bord et $h \geq 2h_{ef}$
> Passende Ringe für den einzelnen Veranker, ohne Achsenabstandseinfluss und des Randabstands und $h \geq 2h_{ef}$

> Azione di taglio non diretta verso il bordo > Coefficiente di sicurezza globale incluso > Coefficiente lato carichi utilizzato = 1,4
> Shear directed away from the edge > General safety factor included > Load increasing safety coefficient used = 1,4
> Action de cisaillement pas dirigée vers le bord > Coefficient de sécurité générale inclu > Coefficient côté charge utilisé = 1,4
> Queraktion nicht an den Rand gerichtet > Generelle Sicherheitskoeffizient inbegriffen > Verwendeter Lasterhöhungssicherheitskoeffizient = 1,4



MIN Dati di carico con profondità effettiva ancoraggio MINIMA > Load data with MINIMUM effective anchorage depth Donnes de charge avec profondeur efficace d'ancrage MINIMALE > Lastdaten mit MINIMALER effektiven Verankerungstiefe

MATERIALE MATERIAL	BARRA ROD	DIAMETRO BARRA ROD DIAMETER	PROFONDITÀ EFF. ANCORAGGIO EFFECTIVE ANCHORAGE DEPTH	CARICO ULTIMO MEDIO A TRAZIONE ULTIMATE TENSION LOAD	CARICO ULTIMO MEDIO A TAGLIO ULTIMATE SHEAR LOAD	CARICO CARATTERISTICO A TRAZIONE CHARACTERISTIC TENSILE LOAD	CARICO CARATTERISTICO A TAGLIO CHARACTERISTIC SHEAR LOAD	CARICO AMMISSIBILE A TRAZIONE ADMISSIBLE TENSILE LOAD	CARICO AMMISSIBILE A TAGLIO ADMISSIBLE SHEAR LOAD
		d [mm]	$h_{ef MIN}$ [mm]	N_{rum} [kN]	V_{rum} [kN]	N_{rk} [kN]	V_{rk} [kN]	N_{rec} [kN]	V_{rec} [kN]
C20/25 Calcestruzzo non fessurato Non cracked Concrete Beton non fissuré Ungerissener Beton  ≥ 5.8	≥ 5.8	M 8	60	19,0	11,4	19,0	9,5	9,0	5,4
	≥ 5.8	M 10	70	30,2	18,1	28,6	15,1	13,6	8,6
	≥ 5.8	M 12	80	39,7	26,3	35,2	21,9	16,7	12,5
	≥ 5.8	M 16	100	56,4	48,9	48,9	40,8	23,3	23,3

MED Dati di carico con profondità effettiva ancoraggio MEDIA > Load data with MEDIUM effective anchorage depth Donnes de charge avec profondeur efficace d'ancrage MOYENNE > Lastdaten mit MITTLERER effektiven Verankerungstiefe

MATERIALE MATERIAL	BARRA ROD	DIAMETRO BARRA ROD DIAMETER	PROFONDITÀ EFF. ANCORAGGIO EFFECTIVE ANCHORAGE DEPTH	CARICO ULTIMO MEDIO A TRAZIONE ULTIMATE TENSION LOAD	CARICO ULTIMO MEDIO A TAGLIO ULTIMATE SHEAR LOAD	CARICO CARATTERISTICO A TRAZIONE CHARACTERISTIC TENSILE LOAD	CARICO CARATTERISTICO A TAGLIO CHARACTERISTIC SHEAR LOAD	CARICO AMMISSIBILE A TRAZIONE ADMISSIBLE TENSILE LOAD	CARICO AMMISSIBILE A TAGLIO ADMISSIBLE SHEAR LOAD
		d [mm]	$h_{ef MED}$ [mm]	N_{rum} [kN]	V_{rum} [kN]	N_{rk} [kN]	V_{rk} [kN]	N_{rec} [kN]	V_{rec} [kN]
C20/25 Calcestruzzo non fessurato Non cracked Concrete Beton non fissuré Ungerissener Beton  ≥ 5.8	≥ 5.8	M 8	80	19,0	11,4	19,0	9,5	9,0	5,4
	≥ 5.8	M 10	90	30,2	18,1	30,2	15,1	14,3	8,6
	≥ 5.8	M 12	110	43,8	26,3	43,8	21,9	20,8	12,5
	≥ 5.8	M 16	125	70,5	48,9	61,2	40,8	29,2	23,3

MAX Dati di carico con profondità effettiva ancoraggio MASSIMO > Load data with MAXIMUM effective anchorage depth Donnes de charge avec profondeur efficace d'ancrage MAXIMUM > Lastdaten mit MAXIMALER effektiven Verankerungstiefe

MATERIALE MATERIAL	BARRA ROD	DIAMETRO BARRA ROD DIAMETER	PROFONDITÀ EFF. ANCORAGGIO EFFECTIVE ANCHORAGE DEPTH	CARICO ULTIMO MEDIO A TRAZIONE ULTIMATE TENSION LOAD	CARICO ULTIMO MEDIO A TAGLIO ULTIMATE SHEAR LOAD	CARICO CARATTERISTICO A TRAZIONE CHARACTERISTIC TENSILE LOAD	CARICO CARATTERISTICO A TAGLIO CHARACTERISTIC SHEAR LOAD	CARICO AMMISSIBILE A TRAZIONE ADMISSIBLE TENSILE LOAD	CARICO AMMISSIBILE A TAGLIO ADMISSIBLE SHEAR LOAD
		d [mm]	$h_{ef MAX}$ [mm]	N_{rum} [kN]	V_{rum} [kN]	N_{rk} [kN]	V_{rk} [kN]	N_{rec} [kN]	V_{rec} [kN]
C20/25 Calcestruzzo non fessurato Non cracked Concrete Beton non fissuré Ungerissener Beton  8.8	8.8	M 8	160	29,2	17,5	29,2	14,6	13,9	8,3
	8.8	M 10	200	46,4	27,8	46,4	23,2	22,1	13,2
	8.8	M 12	240	67,4	40,4	67,4	33,7	32,1	19,2
	8.8	M 16	320	125,0	75,0	125,0	62,5	59,5	35,7



> **Dati carico > Load data > Données de charge > Lastdaten**

D N E G L	N_{rum} [kN]	Carico ultimo medio a trazione > Average ultimate tension load > Charge maximum moyenne de traction Durchschnittliche maximale Zuglast
	V_{rum} [kN]	Carico ultimo medio a taglio > Average ultimate shear load > Charge maximum moyenne de cisaillement Durchschnittliche maximale Querlast
	N_{rk} [kN]	Carico caratteristico a trazione > Characteristic tension load > Charge caractéristique de traction Charakteristische Zuglast
	V_{rk} [kN]	Carico caratteristico a taglio > Characteristic shear load > Charge caractéristique de cisaillement Charakteristische Querlast
	N_{rec} [kN]	Carico ammissibile a trazione > Admissible tensile load > Charge admissible de traction > Zulässige Zuglast
	V_{rec} [kN]	Carico ammissibile a taglio > Admissible shear load > Charge admissible de cisaillement > Zulässige Querlast

> Carichi validi per singolo ancorante senza influenza di interasse e distanza dal bordo e $h \geq 2h_{ef}$ > 1kN = 100 Kg
> Loads for single anchor with no influence of spacing and edge distance and with $h \geq 2h_{ef}$
> Charges valables pour chaque ancrage sans influence d'interaxe et distance du bord et $h \geq 2h_{ef}$
> Passende Ringe für den einzelnen Veranker, ohne Achsenabstandseinfluss und des Randabstands und $h \geq 2h_{ef}$

> Azione di taglio non diretta verso il bordo > Coefficiente di sicurezza globale incluso > Coefficiente lato carichi utilizzato = 1,4
> Shear directed away from the edge > General safety factor included > Load increasing safety coefficient used = 1,4
> Action de cisaillement pas dirigée vers le bord > Coefficient de sécurité générale inclu > Coefficient côté charge utilisé = 1,4
> Queraktion nicht an den Rand gerichtet > Generelle Sicherheitskoeffizient inbegriffen > Verwendeter Lasterhöhungssicherheitskoeffizient = 1,4

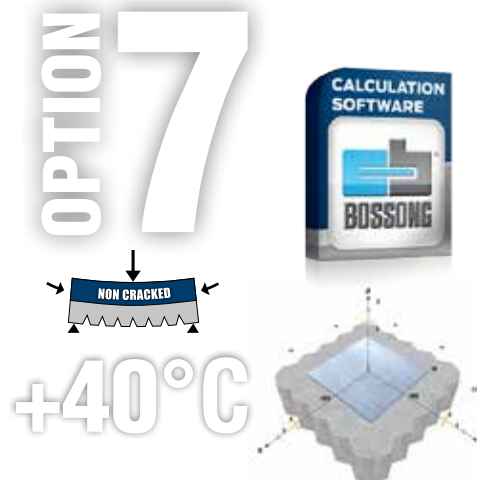

MIN Dati di carico con profondità effettiva ancoraggio MINIMA > Load data with MINIMUM effective anchorage depth
Donnes de charge avec profondeur efficace d'ancrage MINIMALE > Lastdaten mit MINIMALER effektiven Verankerungstiefe

MATERIALE MATERIAL	BARRA ROD	DIAMETRO BARRA ROD DIAMETER	PROFONDITÀ EFF. ANCORAGGIO EFFECTIVE ANCHORAGE DEPTH	CARICO ULTIMO MEDIO A TRAZIONE ULTIMATE TENSION LOAD	CARICO ULTIMO MEDIO A TAGLIO ULTIMATE SHEAR LOAD	CARICO CARATTERISTICO A TRAZIONE CHARACTERISTIC TENSILE LOAD	CARICO CARATTERISTICO A TAGLIO CHARACTERISTIC SHEAR LOAD	CARICO AMMISSIBILE A TRAZIONE ADMISSIBLE TENSILE LOAD	CARICO AMMISSIBILE A TAGLIO ADMISSIBLE SHEAR LOAD
		d [mm]	$h_{ef MIN}$ [mm]	N_{rum} [kN]	V_{rum} [kN]	N_{rk} [kN]	V_{rk} [kN]	N_{rec} [kN]	V_{rec} [kN]
C20/25 Calcestruzzo non fessurato Non cracked Concrete Beton non fissuré Ungerissener Beton  ≥ 5.8	≥ 5.8	M 8	60	19,0	11,4	19,0	9,5	9,0	5,4
	≥ 5.8	M 10	70	30,2	18,1	27,4	15,1	13,0	8,6
	≥ 5.8	M 12	80	39,7	26,3	33,8	21,9	16,1	12,5
	≥ 5.8	M 16	100	56,4	48,9	47,0	40,8	22,3	23,3

MED Dati di carico con profondità effettiva ancoraggio MEDIA > Load data with MEDIUM effective anchorage depth
Donnes de charge avec profondeur efficace d'ancrage MOYENNE > Lastdaten mit MITTLERER effektiven Verankerungstiefe

MATERIALE MATERIAL	BARRA ROD	DIAMETRO BARRA ROD DIAMETER	PROFONDITÀ EFF. ANCORAGGIO EFFECTIVE ANCHORAGE DEPTH	CARICO ULTIMO MEDIO A TRAZIONE ULTIMATE TENSION LOAD	CARICO ULTIMO MEDIO A TAGLIO ULTIMATE SHEAR LOAD	CARICO CARATTERISTICO A TRAZIONE CHARACTERISTIC TENSILE LOAD	CARICO CARATTERISTICO A TAGLIO CHARACTERISTIC SHEAR LOAD	CARICO AMMISSIBILE A TRAZIONE ADMISSIBLE TENSILE LOAD	CARICO AMMISSIBILE A TAGLIO ADMISSIBLE SHEAR LOAD
		d [mm]	$h_{ef MED}$ [mm]	N_{rum} [kN]	V_{rum} [kN]	N_{rk} [kN]	V_{rk} [kN]	N_{rec} [kN]	V_{rec} [kN]
C20/25 Calcestruzzo non fessurato Non cracked Concrete Beton non fissuré Ungerissener Beton  ≥ 5.8	≥ 5.8	M 8	80	19,0	11,4	19,0	9,5	9,0	5,4
	≥ 5.8	M 10	90	30,2	18,1	30,2	15,1	14,3	8,6
	≥ 5.8	M 12	110	43,8	26,3	43,8	21,9	20,8	12,5
	≥ 5.8	M 16	125	70,5	48,9	58,7	40,8	27,9	23,3

MAX Dati di carico con profondità effettiva ancoraggio MASSIMO > Load data with MAXIMUM effective anchorage depth
Donnes de charge avec profondeur efficace d'ancrage MAXIMUM > Lastdaten mit MAXIMALER effektiven Verankerungstiefe

MATERIALE MATERIAL	BARRA ROD	DIAMETRO BARRA ROD DIAMETER	PROFONDITÀ EFF. ANCORAGGIO EFFECTIVE ANCHORAGE DEPTH	CARICO ULTIMO MEDIO A TRAZIONE ULTIMATE TENSION LOAD	CARICO ULTIMO MEDIO A TAGLIO ULTIMATE SHEAR LOAD	CARICO CARATTERISTICO A TRAZIONE CHARACTERISTIC TENSILE LOAD	CARICO CARATTERISTICO A TAGLIO CHARACTERISTIC SHEAR LOAD	CARICO AMMISSIBILE A TRAZIONE ADMISSIBLE TENSILE LOAD	CARICO AMMISSIBILE A TAGLIO ADMISSIBLE SHEAR LOAD
		d [mm]	$h_{ef MAX}$ [mm]	N_{rum} [kN]	V_{rum} [kN]	N_{rk} [kN]	V_{rk} [kN]	N_{rec} [kN]	V_{rec} [kN]
C20/25 Calcestruzzo non fessurato Non cracked Concrete Beton non fissuré Ungerissener Beton  8.8	8.8	M 8	160	29,2	17,5	29,2	14,6	13,9	8,3
	8.8	M 10	200	46,4	27,8	46,4	23,2	22,1	13,2
	8.8	M 12	240	67,4	40,4	67,4	33,7	32,1	19,2
	8.8	M 16	320	125,0	75,0	125,0	62,5	59,5	35,7



SCHEDA TECNICA TECHNICAL DATA SHEET FICHE TECHNIQUE TECHNISCHES DATENBLATT

> Dati carico > Load data > Données de charge > Lastdaten

D E N G E L	N_{rum} [kN]	Carico ultimo medio a trazione > Average ultimate tension load > Charge maximum moyenne de traction Durchschnittliche maximale Zuglast
	V_{rum} [kN]	Carico ultimo medio a taglio > Average ultimate shear load > Charge maximum moyenne de cisaillement Durchschnittliche maximale Querlast
	N_{rk} [kN]	Carico caratteristico a trazione > Characteristic tension load > Charge caractéristique de traction Caratteristica Zuglast
	V_{rk} [kN]	Carico caratteristico a taglio > Characteristic shear load > Charge caractéristique de cisaillement Caratteristica Querlast
	N_{rec} [kN]	Carico ammissibile a trazione > Admissible tensile load > Charge admissible de traction > Zulässige Zuglast
	V_{rec} [kN]	Carico ammissibile a taglio > Admissible shear load > Charge admissible de cisaillement > Zulässige Querlast

> Carichi validi per singolo ancorante senza influenza di interasse e distanza dal bordo e $h \geq 2h_{ef}$ > 1kN = 100 Kg
> Loads for single anchor with no influence of spacing and edge distance and with $h \geq 2h_{ef}$
> Charges valables pour chaque ancrage sans influence d'interaxe et distance du bord et $h \geq 2h_{ef}$
> Passende Ringe für den einzelnen Veranker, ohne Achsenabstandseinfluss und des Randabstands und $h \geq 2h_{ef}$

> Azione di taglio non diretta verso il bordo > Coefficiente di sicurezza globale incluso > Coefficiente lato carichi utilizzato = 1,4
> Shear directed away from the edge > General safety factor included > Load increasing safety coefficient used = 1,4
> Action de cisaillement pas dirigée vers le bord > Coefficient de sécurité générale inclu > Coefficient côté charge utilisé = 1,4
> Queraktion nicht an den Rand gerichtet > Generelle Sicherheitskoeffizient inbegriffen > Verwendeter Lasterhöhungssicherheitskoeffizient = 1,4



MIN Dati di carico con profondità effettiva ancoraggio MINIMA > Load data with MINIMUM effective anchorage depth Donnes de charge avec profondeur efficace d'ancrage MINIMALE > Lastdaten mit MINIMALER effektiven Verankerungstiefe

MATERIALE MATERIAL	DIAMETRO BARRA ROD DIAMETER	PROFONDITÀ EFF. ANCORAGGIO EFFECTIVE ANCHORAGE DEPTH	CARICO ULTIMO MEDIO A TRAZIONE ULTIMATE TENSION LOAD	CARICO ULTIMO MEDIO A TAGLIO ULTIMATE SHEAR LOAD	CARICO CARATTERISTICO A TRAZIONE CHARACTERISTIC TENSILE LOAD	CARICO CARATTERISTICO A TAGLIO CHARACTERISTIC SHEAR LOAD	CARICO AMMISSIBILE A TRAZIONE ADMISSIBLE TENSILE LOAD	CARICO AMMISSIBILE A TAGLIO ADMISSIBLE SHEAR LOAD
			N_{rum} [kN]	V_{rum} [kN]	N_{rk} [kN]	V_{rk} [kN]	N_{rec} [kN]	V_{rec} [kN]
C20/25 Calcestruzzo non fessurato Non cracked Concrete Beton non fissuré Ungerissener Beton 	\emptyset 8	60	21,6	16,2	19,2	13,5	7,6	7,7
	\emptyset 10	70	27,9	25,4	24,8	21,2	9,8	12,1
	\emptyset 12	80	37,6	36,6	31,5	30,5	12,5	17,4
	\emptyset 14	80	39,9	49,8	34,8	41,5	13,8	23,7
	\emptyset 16	100	53,6	65,1	45,7	54,2	18,1	31,0

MED Dati di carico con profondità effettiva ancoraggio MEDIA > Load data with MEDIUM effective anchorage depth Donnes de charge avec profondeur efficace d'ancrage MOYENNE > Lastdaten mit MITTLERER effektiven Verankerungstiefe

MATERIALE MATERIAL	DIAMETRO BARRA ROD DIAMETER	PROFONDITÀ EFF. ANCORAGGIO EFFECTIVE ANCHORAGE DEPTH	CARICO ULTIMO MEDIO A TRAZIONE ULTIMATE TENSION LOAD	CARICO ULTIMO MEDIO A TAGLIO ULTIMATE SHEAR LOAD	CARICO CARATTERISTICO A TRAZIONE CHARACTERISTIC TENSILE LOAD	CARICO CARATTERISTICO A TAGLIO CHARACTERISTIC SHEAR LOAD	CARICO AMMISSIBILE A TRAZIONE ADMISSIBLE TENSILE LOAD	CARICO AMMISSIBILE A TAGLIO ADMISSIBLE SHEAR LOAD
			N_{rum} [kN]	V_{rum} [kN]	N_{rk} [kN]	V_{rk} [kN]	N_{rec} [kN]	V_{rec} [kN]
C20/25 Calcestruzzo non fessurato Non cracked Concrete Beton non fissuré Ungerissener Beton 	\emptyset 8	80	27,1	16,2	25,5	13,5	10,1	7,7
	\emptyset 10	90	35,9	25,4	31,9	21,2	12,6	12,1
	\emptyset 12	110	51,7	36,6	43,3	30,5	17,2	17,4
	\emptyset 14	125	62,4	49,8	54,4	41,5	21,6	23,7
	\emptyset 16	140	75,0	65,1	64,0	54,2	25,4	31,0

MAX Dati di carico con profondità effettiva ancoraggio MASSIMO > Load data with MAXIMUM effective anchorage depth Donnes de charge avec profondeur efficace d'ancrage MAXIMUM > Lastdaten mit MAXIMALER effektiven Verankerungstiefe

MATERIALE MATERIAL	DIAMETRO BARRA ROD DIAMETER	PROFONDITÀ EFF. ANCORAGGIO EFFECTIVE ANCHORAGE DEPTH	CARICO ULTIMO MEDIO A TRAZIONE ULTIMATE TENSION LOAD	CARICO ULTIMO MEDIO A TAGLIO ULTIMATE SHEAR LOAD	CARICO CARATTERISTICO A TRAZIONE CHARACTERISTIC TENSILE LOAD	CARICO CARATTERISTICO A TAGLIO CHARACTERISTIC SHEAR LOAD	CARICO AMMISSIBILE A TRAZIONE ADMISSIBLE TENSILE LOAD	CARICO AMMISSIBILE A TAGLIO ADMISSIBLE SHEAR LOAD
			N_{rum} [kN]	V_{rum} [kN]	N_{rk} [kN]	V_{rk} [kN]	N_{rec} [kN]	V_{rec} [kN]
C20/25 Calcestruzzo non fessurato Non cracked Concrete Beton non fissuré Ungerissener Beton 	\emptyset 8	160	27,1	16,2	27,1	13,5	13,4	7,7
	\emptyset 10	200	42,4	25,4	42,4	21,2	21,0	12,1
	\emptyset 12	240	61,0	36,6	61,0	30,5	30,2	17,4
	\emptyset 14	280	83,1	49,8	83,1	41,5	41,2	23,7
	\emptyset 16	320	108,5	65,1	108,5	54,2	53,8	31,0



> **Dati carico > Load data > Données de charge > Lastdaten**

D E N G E L	N_{rum} [kN]	Carico ultimo medio a trazione > Average ultimate tension load > Charge maximum moyenne de traction Durchschnittliche maximale Zuglast
	V_{rum} [kN]	Carico ultimo medio a taglio > Average ultimate shear load > Charge maximum moyenne de cisaillement Durchschnittliche maximale Querlast
	N_{rk} [kN]	Carico caratteristico a trazione > Characteristic tension load > Charge caractéristique de traction Charakteristische Zuglast
	V_{rk} [kN]	Carico caratteristico a taglio > Characteristic shear load > Charge caractéristique de cisaillement Charakteristische Querlast
	N_{rec} [kN]	Carico ammissibile a trazione > Admissible tensile load > Charge admissible de traction > Zulässige Zuglast
	V_{rec} [kN]	Carico ammissibile a taglio > Admissible shear load > Charge admissible de cisaillement > Zulässige Querlast

> Carichi validi per singolo ancorante senza influenza di interasse e distanza dal bordo e $h \geq 2h_{ef}$ > 1kN = 100 Kg
> Loads for single anchor with no influence of spacing and edge distance and with $h \geq 2h_{ef}$
> Charges valables pour chaque ancrage sans influence d'interaxe et distance du bord et $h \geq 2h_{ef}$
> Passende Ringe für den einzelnen Veranker, ohne Achsenabstandseinfluss und des Randabstands und $h \geq 2h_{ef}$

> Azione di taglio non diretta verso il bordo > Coefficiente di sicurezza globale incluso > Coefficiente lato carichi utilizzato = 1,4
> Shear directed away from the edge > General safety factor included > Load increasing safety coefficient used = 1,4
> Action de cisaillement pas dirigée vers le bord > Coefficient de sécurité générale inclu > Coefficient côté charge utilisé = 1,4
> Queraktion nicht an den Rand gerichtet > Generelle Sicherheitskoeffizient inbegriffen > Verwendeter Lasterhöhungssicherheitskoeffizient = 1,4

OPTION 7

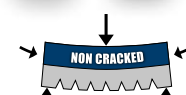

+40°C

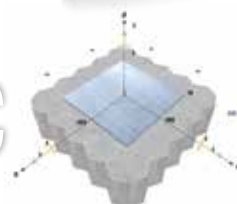

MIN Dati di carico con profondità effettiva ancoraggio MINIMA > Load data with MINIMUM effective anchorage depth
Donnes de charge avec profondeur efficace d'ancrage MINIMALE > Lastdaten mit MINIMALER effektiven Verankerungstiefe

MATERIALE MATERIAL	DIAMETRO BARRA ROD DIAMETER	PROFONDITÀ EFF. ANCORAGGIO EFFECTIVE ANCHORAGE DEPTH	CARICO ULTIMO MEDIO A TRAZIONE ULTIMATE TENSION LOAD	CARICO ULTIMO MEDIO A TAGLIO ULTIMATE SHEAR LOAD	CARICO CARATTERISTICO A TRAZIONE CHARACTERISTIC TENSILE LOAD	CARICO CARATTERISTICO A TAGLIO CHARACTERISTIC SHEAR LOAD	CARICO AMMISSIBILE A TRAZIONE ADMISSIBLE TENSILE LOAD	CARICO AMMISSIBILE A TAGLIO ADMISSIBLE SHEAR LOAD
			N _{rum} [kN]	V _{rum} [kN]	N _{rk} [kN]	V _{rk} [kN]	N _{rec} [kN]	V _{rec} [kN]
C20/25 Calcestruzzo non fessurato Non cracked Concrete Beton non fissuré Ungerissener Beton 	Ø 8	60	21,6	16,2	18,4	13,5	7,3	7,7
	Ø 10	70	27,9	25,4	23,8	21,2	9,4	12,1
	Ø 12	80	37,6	36,6	30,2	30,5	12,0	17,4
	Ø 14	80	39,9	49,8	33,4	41,5	13,2	23,7
	Ø 16	100	53,6	65,1	43,8	54,2	17,4	31,0

MED Dati di carico con profondità effettiva ancoraggio MEDIA > Load data with MEDIUM effective anchorage depth
Donnes de charge avec profondeur efficace d'ancrage MOYENNE > Lastdaten mit MITTLERER effektiven Verankerungstiefe

MATERIALE MATERIAL	DIAMETRO BARRA ROD DIAMETER	PROFONDITÀ EFF. ANCORAGGIO EFFECTIVE ANCHORAGE DEPTH	CARICO ULTIMO MEDIO A TRAZIONE ULTIMATE TENSION LOAD	CARICO ULTIMO MEDIO A TAGLIO ULTIMATE SHEAR LOAD	CARICO CARATTERISTICO A TRAZIONE CHARACTERISTIC TENSILE LOAD	CARICO CARATTERISTICO A TAGLIO CHARACTERISTIC SHEAR LOAD	CARICO AMMISSIBILE A TRAZIONE ADMISSIBLE TENSILE LOAD	CARICO AMMISSIBILE A TAGLIO ADMISSIBLE SHEAR LOAD
			N _{rum} [kN]	V _{rum} [kN]	N _{rk} [kN]	V _{rk} [kN]	N _{rec} [kN]	V _{rec} [kN]
C20/25 Calcestruzzo non fessurato Non cracked Concrete Beton non fissuré Ungerissener Beton 	Ø 8	80	27,1	16,2	24,5	13,5	9,7	7,7
	Ø 10	90	35,9	25,4	30,6	21,2	12,1	12,1
	Ø 12	110	51,7	36,6	41,5	30,5	16,5	17,4
	Ø 14	125	62,4	49,8	52,2	41,5	20,7	23,7
	Ø 16	140	75,0	65,1	61,4	54,2	24,3	31,0







MAX Dati di carico con profondità effettiva ancoraggio MASSIMO > Load data with MAXIMUM effective anchorage depth
Donnes de charge avec profondeur efficace d'ancrage MAXIMUM > Lastdaten mit MAXIMALER effektiven Verankerungstiefe

MATERIALE MATERIAL	DIAMETRO BARRA ROD DIAMETER	PROFONDITÀ EFF. ANCORAGGIO EFFECTIVE ANCHORAGE DEPTH	CARICO ULTIMO MEDIO A TRAZIONE ULTIMATE TENSION LOAD	CARICO ULTIMO MEDIO A TAGLIO ULTIMATE SHEAR LOAD	CARICO CARATTERISTICO A TRAZIONE CHARACTERISTIC TENSILE LOAD	CARICO CARATTERISTICO A TAGLIO CHARACTERISTIC SHEAR LOAD	CARICO AMMISSIBILE A TRAZIONE ADMISSIBLE TENSILE LOAD	CARICO AMMISSIBILE A TAGLIO ADMISSIBLE SHEAR LOAD
			N _{rum} [kN]	V _{rum} [kN]	N _{rk} [kN]	V _{rk} [kN]	N _{rec} [kN]	V _{rec} [kN]
C20/25 Calcestruzzo non fessurato Non cracked Concrete Beton non fissuré Ungerissener Beton 	Ø 8	160	27,1	16,2	27,1	13,5	13,4	7,7
	Ø 10	200	42,4	25,4	42,4	21,2	21,0	12,1
	Ø 12	240	61,0	36,6	61,0	30,5	30,2	17,4
	Ø 14	280	83,1	49,8	83,1	41,5	41,2	23,7
	Ø 16	320	108,5	65,1	108,5	54,2	53,8	31,0

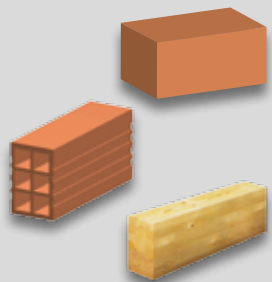

**SCHEDA TECNICA
TECHNICAL DATA SHEET
FICHE TECHNIQUE
TECHNISCHES DATENBLATT**

MASONRY & WOOD

MATERIALE MATERIAL	TIPOLOGIA DI BARRA TYPE OF ROD	DIAMETRO BARRA ROD DIAMETER	CARICO ULTIMO MEDIO A TRAZIONE ULTIMATE TENSION LOAD	CARICO ULTIMO MEDIO A TAGLIO ULTIMATE SHEAR LOAD	CARICO AMMISSIBILE A TRAZIONE ADMISSIBLE TENSILE LOAD	CARICO AMMISSIBILE A TAGLIO ADMISSIBLE SHEAR LOAD
			N _{Rum} [kN]	V _{Rum} [kN]	N _{rec} [kN]	V _{rec} [kN]
Mattone pieno Solid Brick Brique pleine Vollmauerwerk  ≥ 4.6 / A2-70 / A4-70 	≥ 4.6 A2-70 A4 -70	M8	 > Dati di carico raccomandati per applicazioni su materiali base di medie caratteristiche meccaniche. Vista la varietà dei substrati in muratura e/o legno per applicazioni su supporti differenti da quelli considerati, i valori di carico dovranno essere ricavati tramite opportune prove in situ. > Recommended loads for applications on base materials with medium strength characteristics. For different masonry and/or wood base materials, load values must be obtained with in situ tests.		2,0	3,0
	≥ 4.6 A2-70 A4 -70	M10		2,6	3,4	
	≥ 4.6 A2-70 A4 -70	M12		2,8	3,9	
	≥ 4.6 A2-70 A4 -70	M16		4,0	4,2	
Materiale forato Hollow Material Material creuse Lochziegeln  ≥ 4.6 / A2-70 / A4-70 	≥ 4.6 A2-70 A4 -70	M8		0,9	2,0	
	≥ 4.6 A2-70 A4 -70	M10		0,9	2,0	
	≥ 4.6 A2-70 A4 -70	M12		0,9	2,5	
Legno lamellare Laminated Timber Timber Holz  ≥ 4.6 / A2-70 / A4-70 	≥ 4.6 A2-70 A4 -70	M8		3,2	> Per valori a taglio riferirsi alle istruzioni CNR-DT 206/2007 (7.10.2.3)	
	≥ 4.6 A2-70 A4 -70	M10		4,2	> For shear loads refer to CNR-DT 206/2007 (7.10.2.3)	
	≥ 4.6 A2-70 A4 -70	M12		6,1	> For shear loads refer to CNR-DT 206/2007 (7.10.2.3)	
	≥ 4.6 A2-70 A4 -70	M16		10,7	> For shear loads refer to CNR-DT 206/2007 (7.10.2.3)	



> Procedura di installazione > Installation procedure > Procédure d'installation > Installationsverfahren

01

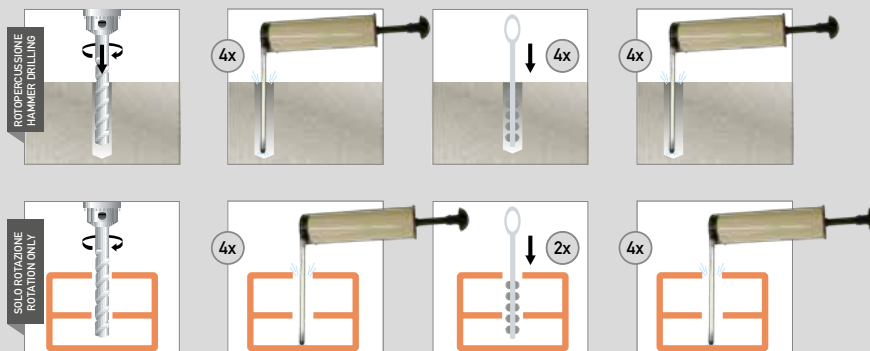

- > Eseguire il foro controllandone la perpendicolarità. Soffiare il foro con apposita pompa soffiante (o aria compressa), eseguire operazione di pulizia della superficie laterale del foro con apposito scovolino metallico, soffiare nuovamente il foro fino a che non fuoriesca più polvere e/o altro materiale residuo. Si raccomanda un'attenta pulizia della superficie laterale del foro con scovolino metallico.
- > Drill the hole and check its perpendicularity. Blow the hole with an appropriate pump blower (or compression air), clean the lateral surface of the hole with an appropriate steel brush, blow again in the hole until there is no dust and/or any residual material inside. We strongly recommend use of the steel brush to clean hole sides.

- > Réaliser le trou en contrôlant la perpendicularité. Souffler dans le trou avec la pompe soufflante prévue (ou de l'air comprimé), effectuer l'opération de nettoyage de la surface latérale du trou avec un écouvillon métallique, souffler à nouveau dans le trou jusqu'à ce qu'il n'en sorte plus de poussière et/ou d'autres matières résiduelles. Nous recommandons l'utilisation d'écouvillon métallique pour le nettoyage de la surface latérale du trou.
- > Stellen Sie die BOHRLOCHUNG unter Kontrolle der Rechtwinkigkeit her. Blasen Sie die BOHRLOCHUNG mit einer entsprechenden Pumpe (oder Druckluft) durch, nehmen Sie eine Reinigung der seitlichen Oberflächen der BOHRLOCHUNG mit einer Bürste von Metall vor, blasen Sie die BOHRLOCHUNG erneut durch, bis kein Pulver und / oder andere Materialrückstände mehr austreten. Insbesondere ist die Benutzung der Metallbürste für die Reinigung der seitlichen Oberfläche der BOHRLOCHUNG notwendig.

02

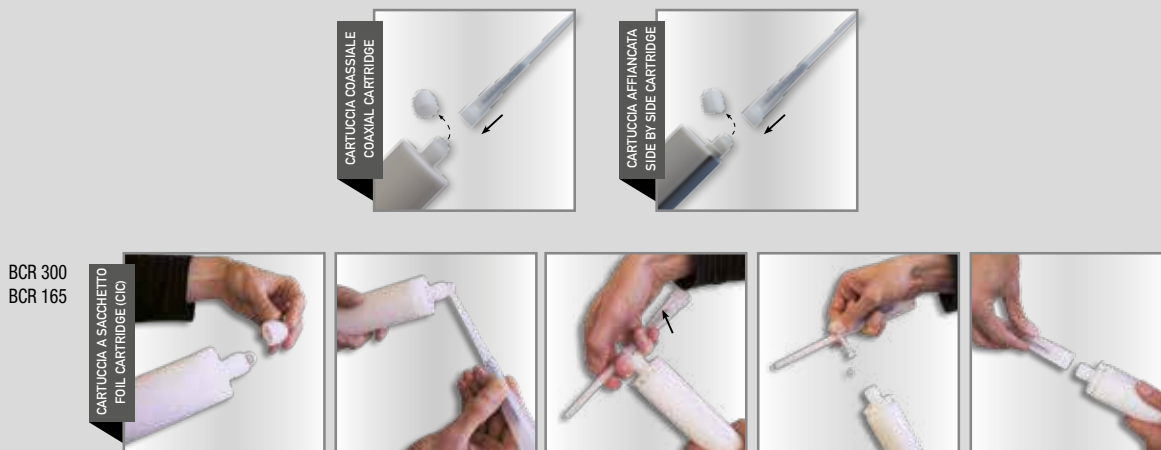

- > Svitare il tappo, avvitare il miscelatore e inserire la cartuccia nella pompa usando protezioni per mani e viso. Nei formati 300 ml e 165 ml svitare il tappo, estrarre la clip metallica secondo le seguenti operazioni:
 - inserire il miscelatore nell'asola dell'estrattore in plastica,
 - tirare l'estrattore per sfilare la clip metallica di chiusura del sacchetto.
 Dopodiché avvitare il miscelatore, inserire la cartuccia nella pompa usando protezioni per mani e viso.
- > Unscrew the front cup, screw on the mixer and insert the cartridge in the gun. Use protections for hands and face. With the size 300 ml and 165 ml, unscrew the front cup, pull-out the steel closing clip according to the following operations:
 - insert the mixer in the eye of the plastic extractor,
 - pull the extractor to unhook the steel closing clip of the foil.
 After that, screw on the mixer and insert the cartridge in the gun. Use protections for hands and face.

- > Dévisser le bouchon, visser le mélangeur et insérer la cartouche dans la pompe en utilisant les protections pour les mains et le visage. Pour les formats 300 ml et 165 ml, dévisser le bouchon, extraire le clip métallique selon les opérations suivantes:
 - insérer le mélangeur dans la fente de l'extracteur en plastique,
 - tirer l'extracteur pour défaire le clip métallique de fermeture du sachet.
 Après cela, visser le mélangeur, insérer la cartouche dans la pompe en utilisant les protections pour les mains et le visage.
- > Lösen Sie den Verschluss, schrauben Sie den Mischer an und bringen Sie den Einsatz in der Pumpe unter Verwendung von Schutzmitteln für Hände und Gesicht an. Lösen Sie bei den Formaten zu 300 ml und 165 ml den Verschluss und ziehen Sie die Metallklemme entsprechend folgender Vorgehensweise heraus:
 - fügen Sie den Mischer in das Langloch der Ausziehvorrichtung aus Kunststoff ein,
 - Ziehen Sie die Ausziehvorrichtung heraus, um die Metallklemme zum Verschließen des Beutels zu entfernen.
 Schrauben Sie dann den Mischer fest und fügen Sie den Einsatz in die Pumpe unter Verwendung von Schutzmitteln für Hände und Gesicht ein.



SCHEDA TECNICA TECHNICAL DATA SHEET FICHE TECHNIQUE TECHNISCHES DATENBLATT

03

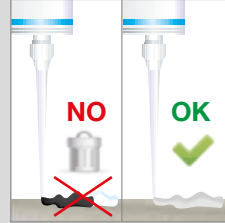

- > Estrudere una prima parte del prodotto assicurandosi che:
 - attraverso il mixer (trasparente) il flusso di prodotto sia composto dalla parte A (colore bianco) e dalla parte B (colore nero).
 - i due componenti si siano completamente miscelati.
 La completa miscelazione è raggiunta quando dal miscelatore il prodotto, ottenuto dall'unione dei due componenti, fuoriesce con colore uniforme. Solo allora la cartuccia è pronta per l'uso.
- > Before starting to use the cartridge, eject a first part of the product, being sure that:
 - Through the mixer (transparent) see that the flux of product is compound of the part A (white colour) end of part B (black colour).
 - the two components are completely mixed.
 The complete mixing is reached only after that the product, obtained by mixing the two component, comes out from the mixer with an uniform colour. Now the cartridge is ready to be used.

- > Extruder une première partie du produit en s'assurant que:
 - travers le mélangeur (transparent) le flux de produit est composé par les composants A (blanc) et B (noir)
 - les deux composants soient complètement mélangés.
 Le mélange complet est atteint quand le produit obtenu par l'union des deux composants sort du mélangeur avec une couleur uniforme. Alors seulement, la cartouche est prête à l'emploi.
- > Ziehen Sie einen ersten Teil des Produktes heraus und prüfen Sie dass:
 - Durch den Mischer (transparent) ist der Fluss des Produktes aus Teil A (weiße Farbe) und Teil B (schwarze Farbe) zusammengesetzt.
 - Die zwei Teilen werden völlig gemischt.
 Die komplette Mischung erfolgt als vom Mischer das Produkt, sich ergebend von den zwei Teilen, mit gleichmäßiger Farbe entweicht. Da ist die Kartusche fertig für die Anwendung.

04

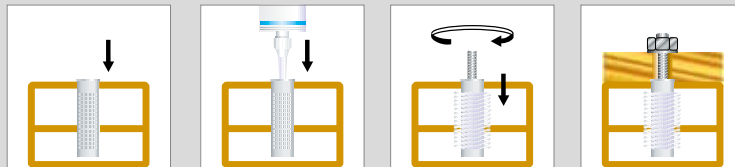
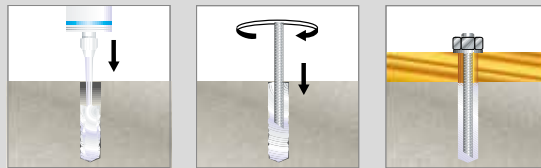

- > 1) Estrudere la resina nel foro fino a riempirlo per 2/3. In caso di materiale forato inserire la gabbietta di plastica e poi estrudere nella gabbietta. 2) Utilizzare una barra filettata tagliata a 45° nell'estremità verso il foro. Prima di inserire la barra verificare che la superficie della stessa sia asciutta, priva di olio ed altri agenti contaminanti. Inserire la barra con un movimento rotatorio per la fuoriuscita delle bolle d'aria. 3) Per l'installazione della barra e la successiva messa in carico rispettare i relativi tempi di posa specificati sia nella scheda tecnica che sull'etichetta del prodotto. 4) Prima della messa in carico verificare l'indurimento del prodotto. 5) La cartuccia può essere riutilizzata successivamente sostituendo il mixer con uno nuovo. Ricordarsi sempre di estrarre una parte del prodotto vedi punto 3.
- > 1) Inject resin into the hole up to fill it 2/3rds. In hollow bricks use the plastic sleeve and inject the resin inside. 2) Use a threaded stud with 45° cut in the side to the hole. Before insert the rod, verify that the element is dry and free oil and other contaminants. Insert threaded stud turning back and forth to avoid presence of air in the fitted hole. 3) For the installation and the following anchor load phase, respect the open time and curing time detailed in the technical data sheet and in the label of the product. 4) Before to load the anchor, check the hardened of the product. 5) The cartridge can be used again screwing the cup and replacing the mixer. Remember to eject a first part of the product, see point 3.

- > 1) Extruder la résine dans le trou jusqu'à le remplir aux 2/3. En cas de matériel troué, insérer la forme en plastique et ensuite extruder dans la forme. 2) Utiliser une barre FILETÉE coupée à 45° à l'extrémité côté trou. Avant d'insérer la barre, vérifier que la surface est sèche, sans rest de huile ou d'autres agents contaminants. Insérer la barre avec un mouvement de rotation pour faire sortir les bulles d'air. 3) Pour l'installation de la barre et le suivant chargement de l'ancrage, respecter les temps de prise indiqués sur la fiche technique et sur la cartouche. 4) Avant de charger l'ancrage, vérifier le durcissement du produit. 5) La cartouche peut être réutilisée par la suite en remplaçant le mixer par un nouveau. Se rappeler de toujours extruder une partie du produit voir point 3.
- > 1) Pressen Sie das Harz in das BOHRLOCH bis diese zu 2/3 gefüllt ist. Bei Lochmaterialien muss der Siebhülse eingefügt und dann in die Hülse gepresst werden. 2) Verwenden Sie einen Gewindestab mit 45°-Schnitt am zur BOHRLOCHUNG zeigenden Ende. Vor dem Einstecken des Gewindestabes prüfen dass seine Fläche trocken, ohne Öl und andere verunreinigende Wirkstoffe ist. Fügen Sie den Stab mit einer Drehbewegung ein, um die Luftblasen austreten zu lassen. 3) Warten Sie die Aushärzeit und Verladungszeit ab, die im technischen Datenblatt und auf dem Etikett des Produktes angegeben sind. 4) Vor der Verladung überprüfen dass das Produkt verhärtet ist. 5) Der Einsatz kann später wiederverwendet werden, indem der Mischer durch einen neuen ersetzt wird. Vergessen Sie nicht, immer einen Teil des Produktes herauszupressen, siehe Punkt 3.

- > **NOTA:** Dati tecnici, di installazione e di carico possono essere oggetto di revisione. Per una versione aggiornata consultare le schede tecniche sul sito www.bossong.com o contattare il nostro Ufficio Tecnico.
- > **WARNING:** Installation and loads technical data can be modified by us. For update technical data sheet see www.bossong.com or be in contact with our Technical Office.

- > **NOTE:** données techniques, d'installation et de charge peuvent être objet de révision. Pour une version mise à jour, consulter les fiches techniques dans le site internet www.bossong.com ou contacter notre Bureau Technique.
- > **ANMERKUNG:** technische Daten, Installationsangaben und Lastdaten können modifiziert werden. Für die aktualisierte Version sind die technischen Blätter auf der Webseite www.bossong.com nachzuschauen, oder unser Technisches Büro soll konsultiert werden.